

GRUNDIG

WORLD RECEIVER

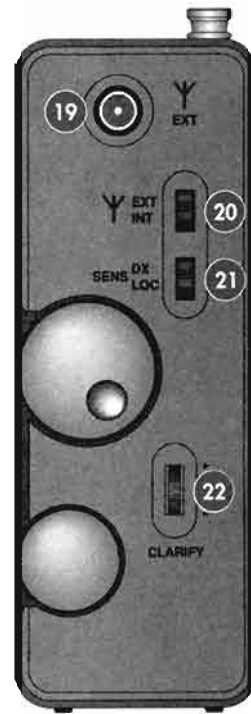

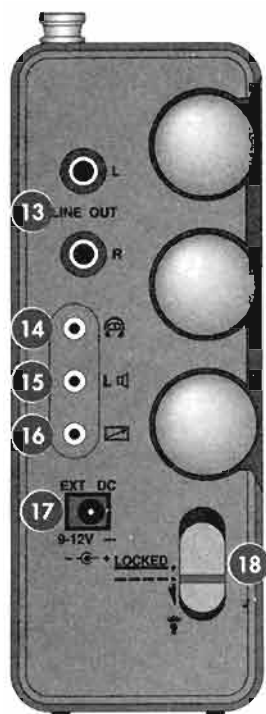

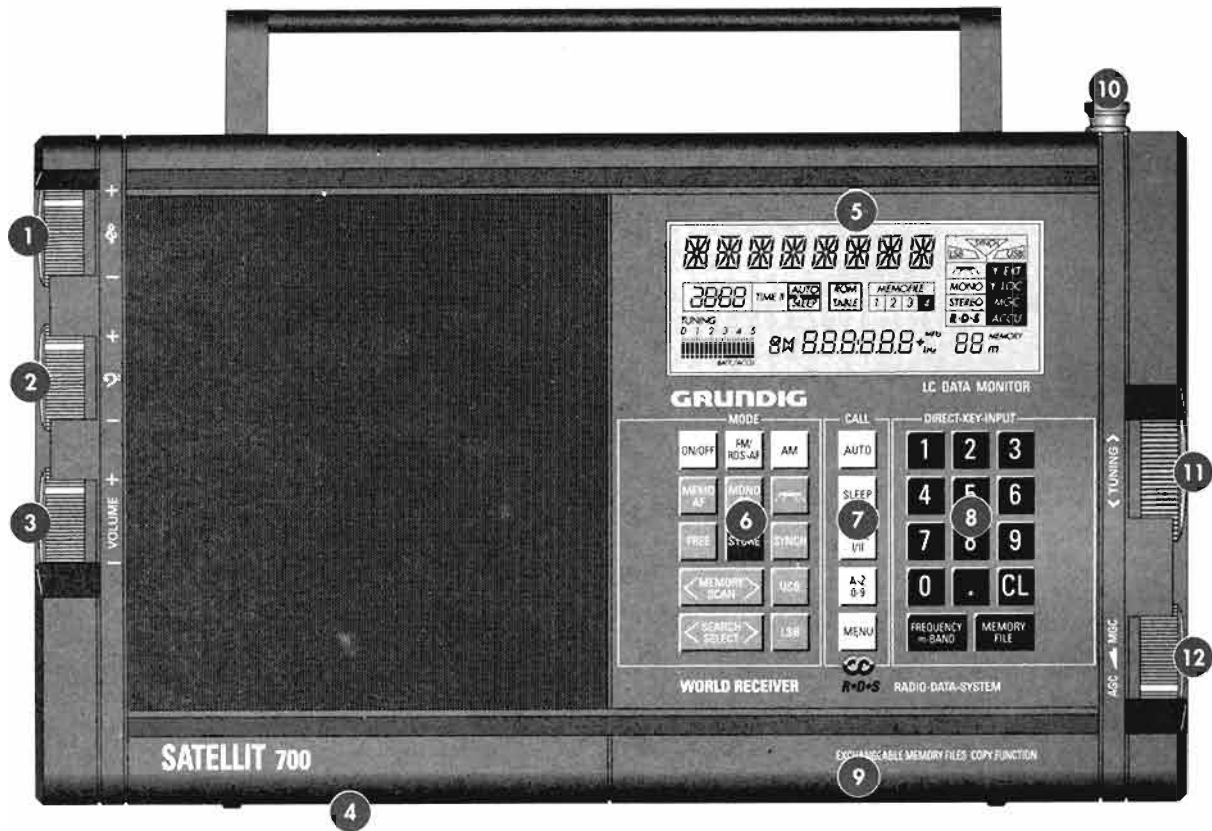

SATELLIT 700

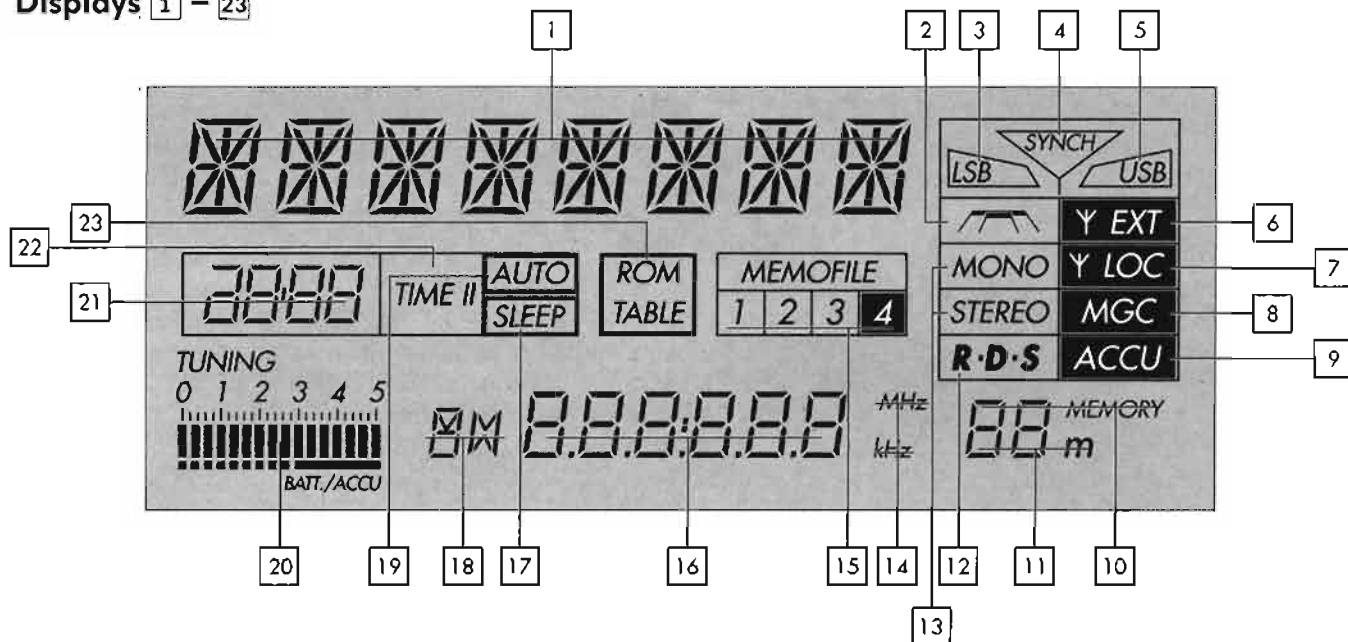

Satellit 700 – LC DATA MONITOR (Display)

Displays 1 – 23



- 1 **8-Digit Alphanumeric Display for**
– Station name
 Appears automatically when receiving an FM (VHF) station which is transmitting RDS (Radio-Data-System) signals. For other stations, you can enter a name of your choice.
– Abbreviations
 e.g., LOCAL (– radio), WEATHER (broadcast), etc.
– Programming functions
 e.g., <MENU>, TIME 1, COPY – etc.
– Comments (marker *)
 e.g., * LOCKED, * NO RDS, etc.
– Error messages (marker **)
 e.g., ** MEMORY, ** FREQ, etc.
- 2  = narrow,  = wide (bandwidth on AM):
LW, MW, SW.
- 3 **LSB (Lower Side Band):**
Lower side band in **SYNCH** mode and on **SSB** reception.
SSB: Single Side Band.
- 4 **SYNCH (Synchronous demodulator):**
 Tuning in the 100 Hz raster on **AM**.
 The synchronous demodulator is switched on.
- 5 **USB (Upper Side Band):**
Upper side band in **SYNCH** mode and on **SSB** reception.
- 6 **Y EXT (reception with an external aerial):**
 The aerial switch  is set to **Y EXT**.
- 7 **Y LOC (local reception on AM):**
 The local/distant switch  is set to **LOC**.
- 8 **MGC (Manual Gain Control):**
 Manual gain control on **AM**
 (LW, MW, SW).
 The switch **AGC**  **MGC**  is set to **MGC**.
- 9 **ACCU**
 The slider switch **ACCU/BATT.** (in battery compartment) is set to **ACCU**. Never set or leave this switch in the **ACCU** position when batteries are fitted in the set.
- 10 **1 – 64 MEMORY (number of station memory position)**
- 11 **SW-m-Band**
AS (AUTO SEARCH) = automatic station search
HA = manual station tuning; direct frequency entry and station search.
AF = RDS Alternative Frequency
- 12 **R·D·S (Radio-Data-System)**
 You are receiving an FM station broadcasting RDS signals.
- 13 **MONO/STEREO (FM mono and stereo reception, respectively)**
- 14 **MHz – kHz (frequency):**
 in **MHz** on FM (VHF), in **kHz** on **AM** (LW, MW, SW).
- 15 **MEMOFILE 1 – 4**
- 16 **Frequency and Switch-On Time 1 or 2, respectively**
- 17 **SLEEP (a sleep time is entered)**
- 18 **LW (Longwave), MW (Mediumwave), SW (Shortwave) and FM (VHF):** selected waveband.
- 19 **AUTO (Automatic):**
 Switching time(s) is (are) programmed and activated.
- 20 **Field Strength and Battery/Accu Check, respectively.**
- 21 **Times of Day (TIME I/TIME II) and Sleep Time**
- 22 **TIME I/TIME II (times of day and switch-on times 1/2):**
 related to the indication .
- 23 **ROM TABLE (ROM-table selected)**

Contents

Satellite 700 – LC DATA MONITOR (Display)	35	Checking the intended station memory position	53
Contents	36	Searching free station memory positions	53
Your Satellit at a Glance	37	Initial allocation of station memory positions	54
Securing the Unit	39	Calling up stored stations	54
Contact Allocation	39	The <MEMORY SCAN> button	54
Power Supply	40	Clearing an occupied station memory position	54
Battery or accumulator operation	40	Entering a station abbreviation	55
Charging time	40	Storing a nome for the MEMOFILE	55
Hints	40	Indicating the name of a MEMOFILE	55
RESET Button	40	Creating a stations memory	56
Data protection	40	Calling up station memory positions	56
Checking the condition of the batteries or accumulators	41	Storing alternative frequencies	56
Mains and charging operation	41	Calling up alternative frequencies	57
Operation on an external DC voltage	41	Erasing alternative frequencies	57
Aerials	42	Going To Sleep to Radio	57
Built in aerials - Aerial connection	42	The Clock	58
User Guide Via the Menu	43	Setting the clock (TIME I)	58
General Operation of the Set	44	Setting the clock (TIME II)	58
Switching on and off	44	Time indication (TIME I/TIME II)	58
Direct entries	44	Automatic Functions	59
Indications and error messages	44	Programming switching times (times 1)	59
Display illumination	45	Programming switchings times (times 2)	60
Tone and volume controls	45	Checking switching times (times 1/2)	60
Waveband selection	45	Clearing switch-on times	60
ROM-Table of the Satellit 700	46	Automatic switching on ond off	60
Selecting frequencies	46	Clearing switching times	61
ROM Table (reception area USA)	46	Timer recordings	61
Selecting the ROM-Table Memory Positions	47	Automatic control of a cassette recorder	61
Step by Step into the World of Shortwave Reception	48	Hint for the Specialized Dealer	61
Station Tuning	49	Special Functions in the FM Wavebands	62
1. Manually	49	RDS (Radio Data System)	62
2. With the numbered buttons	49	Calling up alternative frequencies (AF)	62
3. With the automatic station search button in the FM waveband	50	Special Functions in the AM Wavebands	63
4. Raster tuning in the AM wavebands	50	Individual tuning of the input circuit	63
Entering a Meter Band on SW Reception	51	Bandwidth	63
Storing Stations in Memory – Calling UP Stored Stations – Clearing Stored Stations	52	Synchronous demodulator	63
Memory configuration	52	SSB (Single Side-Band) Reception on SW	64
What can you store?	52	MEMOFILES	65
The frequency tuned to, is it already stored in memory?	53	Specification	66
		Hints – Prescriptions – Accessories	66
		Radio Stations	66

Your Satellite at a Glance

- ① **Treble Control** +/- (Ⓕ)
- ② **Bass Control** +/- (Ⓖ)
- ③ **Volume Control** +/- (VOLUME)
- ④ **Battery Compartment** (in the back of the set)
 - In the battery compartment, at the upper right: slider switch **ACCU/BATT.**
(See scheme in the battery compartment).
- ⑤ **LC DATA MONITOR** (Display)
- ⑥ **MODE buttons** (operating modes)
 - A difference is made between "briefly" and "longer time" when pressing the buttons.
 - briefly = pressing a button **less** than one second;
 - longer time = pressing a button **longer** than one second.

ON/OFF

- For switching on and off.
To prevent inadvertent operation, the function of this button is activated only when pressing it a longer time.

Please observe:
The locking switch (Ⓗ) must **not** be set to "LOCKED", otherwise switching on the set will be **not** possible.

FM/RDS-AF

- For switching on the **FM** (VHF) waveband (Indication ⒾⒸ).
You will hear the station tuned to last in this waveband (Last Station Memory).
- For invoking the **Alternative Frequencies (AF)** which can be received via **RDS** (Radio Data System) when this waveband is selected.

AM

- For switching on the **AM** wavebands (indication ⒾⒹ).
- Further pressures on this button step through the **AM** wavebands in the following order:
LW → MW → SW → LW → MW → etc.
- You will hear the station tuned to last in the respective waveband (Last Station Memory).

MEMO-AF (Alternative Frequency from stations memory)

- Pressing button **briefly** :
Display of the alternative frequencies of **one** station memory position.
- Pressing button a **longer time** :
Automatic stepping through and playing of the alternative frequencies of **one** memory position in a rhythm of 3 seconds.

MONO/Ⓞ (Stereo)

- (Indication ⒾⒺ).
- To switch over from stereo to mono reproduction on **FM** reception, e.g., when stereo reception is noisy or distorted.

- On **AM** reception: Press and hold down this button for performing the individual input circuit tuning with the tuning knob (Ⓘ) (Ⓜ **PR - SEL** in the display Ⓘ).

Ⓘ (indication Ⓘ)

- For changing the bandwidth in the **AM** bands.
- On **FM**: Indication of the RDS error rate (Ⓜ **RDS - Q**, see page 62).

FREE

- Displays the free memory positions in increasing sequence as often as you press or as long as you hold down the button.
(Ⓜ **FREE** and the number of the station memory position appear in the display Ⓘ).
- If all memory positions are occupied, the indication Ⓜ **FULL** appears in the display Ⓘ.
- Clears occupied memory positions after preselection with the buttons **0-9** (press button a longer time).
- Clears alternative frequencies after preselection with the buttons **0-9** (press button briefly).

STORE

- For storing the MEMOFILE name in the memory.
- For displaying the station memory positions which are allocated to the frequency tuned to (Store Compare).
- Press the button **briefly** :
Adds an alternative frequency to a station memory position.
- Press the button a **longer time** :
For initial storing (frequencies, operating functions, and names), and for overwriting memory positions.

SYNCH (synchronous)

- On **AM**, for switching over to the 100 Hz tuning raster, and for switching on the synchronous demodulator (indication Ⓘ). No function on **FM** (VHF).

<MEMORY SCAN>

- Press the button **briefly** :
To call up occupied memory positions . . .
< = in the direction of decreasing position numbers,
> = in the direction of increasing position numbers.
In each case, only the first of 8 possible alternative frequencies, and in addition the name of the station memory position will be displayed. For details see page 54.
- Memory positions which are not occupied are automatically skipped.
- Press button a **longer time** :
Automatic stepping through the memory positions.
- After manual tuning, retrieval of the station position selected last.

USB (Upper Side Band) :

- Upper side band on **SSB** (Single Side Band) reception (indication Ⓘ). No function on **FM** (VHF).

<SEARCH SELECT>

- Press button **briefly** :
 - For starting the automatic station search on **FM** (VHF) in the 50 kHz raster.
 - Manual tuning on **MW** and **LW** in the 9 kHz raster.
- On **MW**, for switching over to the 10 kHz raster (USA raster) via the **MENU**. (For details, see page 43).
- On **SW**, for raster scan within a m-band.

Your Satellit at a Glance

- Next MENU item.
Next cursor position on STORE/FREE.
Next character position when entering a name.
- Press button a **longer time**:
 - On **AM**, for starting the automatic raster search (Raster Scan) in the preselected raster.
 - On **LW**, for starting the automatic raster search in the 9 kHz raster.
 - On **SW**, for starting the automatic raster search:
Raster frequency within the amateur bands: 1 kHz.
Raster frequency within the radio bands: 5 kHz.

LSB (Lower Side Band):

Lower side band on **SSB** reception (indication [3]).
No function on **FM**.

7 **CALL** Buttons

AUTO (Automatic, indication [18])

To prevent inadvertent operation, the function of this button is activated only when pressing the button a longer time.

- For activating the switch-on and switch-off times 1 and 2.
- Automatic mode is only possible when at least one switching time is programmed.

SLEEP (Sleep time, indication [17])

To prevent inadvertent operation, the function of this button is activated only when pressing the button a longer time.

- For entering a sleep time of up to 60 minutes in steps of 10 minutes.

TIME I/TIME II (times of day, indications [21] and [22])

- To select between **TIME I** and **TIME II**.
- For setting and calling up the clock times **I** and **II**.

A - Z/0 - 9

- For entering station names - the first character and the cursor are alternately flashing.
- Pressing the button **<SEARCH SELECT>** moves the cursor left and right.
- With the tuning knob **<TUNING>** [11], it is possible to select the individual characters. To go to the next character, press the **<SEARCH SELECT>** button once again.
- Terminate the entry and store it in memory with the button **A - Z/0 - 9**.
- Pressing the **CL** button terminates entry without storing.

MENU For details, see page 43

- For invoking the menu from radio mode (**<MENU>** in the display [1]).
- For selecting the menu items **TIMER 1**, **TIMER 2**, **COPY**, **LAMP OFF/ON**, **BEEP OFF/ON**, **MW 9 kHz/10 kHz** with the button **<SEARCH SELECT>**.
- For confirming the entries made in the menu with the **MENU** button.
When **<MENU>** is displayed, you can exit the menu mode with the **MENU** button (return to radio mode). If no entries are required (**ON 1/2**, **STATION**, **OFF 1/2**), you can exit the menu also with the **CL** (Clear) button.

8 **DIRECT-KEY-INPUT** Buttons (direct entries) **0-9** and **.**

- Numbered buttons for all numeric entries.
- Button **CL** (Clear) for clearing wrong entries.

FREQUENCY/m-BAND

- For transferring the frequencies entered with the buttons **0-9** and **.** into memory.
- For transferring the SW-m-band entered with the buttons **0-9** into memory.
- When holding down this button, the next SW-m bands are selected one after the other (lower cut-off frequency).
- For temporarily displaying the SW-m band when the stations memory position is shown.

MEMORY/FILE

- For calling up station memory positions (preselection with buttons **0-9**).
The first occupied alternative frequency is selected.
- To go to a different memory file.
- For displaying the MEMOFILE name (hold down button). For details, see page 55.

9 **Flap for Memofile Box**

- The cover can be opened with a coin (slot in bottom part of cover)
- Three exchangeable memory modules (Memofiles) can be plugged into the receptacles behind the flap.
For details, see page 65.

10 **Telescopic Aerial**

- For FM (VHF) and SW reception.
- Can be extended and positioned for best reception.

11 **Tuning Knob (<TUNING>)**

- Tuning steps:
- On **FM** (VHF): 25 kHz
 - On **MW**, **SW** and **LW**: 1 kHz
 - In the modes **SSB** and **SYNCH**: 100 kHz

12 **Switch AGC** **MGC** (on AM)

- AGC** (Automatic Gain Control):
Click-stop position for "normal" radio reception.
- MGC** (Manual Gain Control):
Indication [8].

13 **Phono Sockets** (LINE OUT L/R)

- L = left-hand channel, R = right-hand channel.
- High-level output for driving an amplifier or for making tape recordings.
 - For making recordings, see chapter "Automatic Functions", page 61.

14 **Headphone Jack** (🎧)

- For headphones with 3.5 mm jack plug and 32-2000 Ω impedance.
When connecting a headphone, the built-in loudspeaker is automatically disconnected.

15 **Loudspeaker Jack** (🔊)

- For two external loudspeakers with 3.5 mm jack plug and 8 Ω impedance.
Connecting the external loudspeakers automatically disconnects the built-in loudspeaker.

Your Satellit at a Glance

- ①⑥ **Switch Output Jack controlled by relay** (☑)
- For controlling external units (e.g., a tape recorder).
- ①⑦ **Coaxial Socket 5.5 mm 9 - 12 V = (EXT. DC)**
- For connecting the mains unit NR 90 supplied with the set or for connecting to a 12 V external (board) supply system (- ⚡ +).
- ①⑧ **Locking Switch (LOCKED)**
combined with temporary illumination (☑).
In position **LOCKED** and with the set **switched on**, **all buttons** on the front panel (On/Off switch excluded) and the **<TUNING knob >** ①⑪ are "locked".
Inadvertent misadjustment of the set is thus prevented.

When the set is switched off, it cannot be switched on when this switch is set to **LOCKED**.

 - When actuating one of the **buttons**, the **tuning knob** ①⑪, or when attempting to **switch on** the set, the message **⚡ LOCKED** appears in the display ①.
 - To switch on the temporary illumination, press down the button (position ☑).
- ①⑨ **Coaxial Socket DIN 45325 (Y EXT)**
- Aerial connection for all wavebands.

- ②⑩ **Aerial Switch (Y EXT/INT)**
INT = Telescopic aerial ⑩ effective.
On SW reception, an aerial preamplifier is switched into the aerial circuit.
EXT = External aerial on socket ①⑨ switched on (indication ⑧).
- ②⑪ **Distant/Local Switch (SENS DX/LOC)**
- For optimizing reception quality on **AM** when receiving with the telescopic aerial or an external aerial.
On **MW** and **LW** reception, this switch is only effective when using an **external aerial**.
DX = distant reception = normal position
LOC = local = local reception (indication ⑦).
Due to the much more better SW propagation conditions during the evening and night hours, there may occur interferences during this period.
• If this should be the case, switch the receiver to **LOC**.
- Weak stations, which otherwise would be "covered" by the interference noise, now can also distinctly be received.
- ②⑫ **Fine Tuning (CLARIFY)** on SSB reception.

Securing the Unit

The Satellit can be secured to an appropriate surface. For this, two threaded holes M 4 are provided in its base. Only use screws which are **at least 15 mm** and **max. 19 mm** longer than the thickness of the material to which the Satellit is to be secured. (See Fig.).

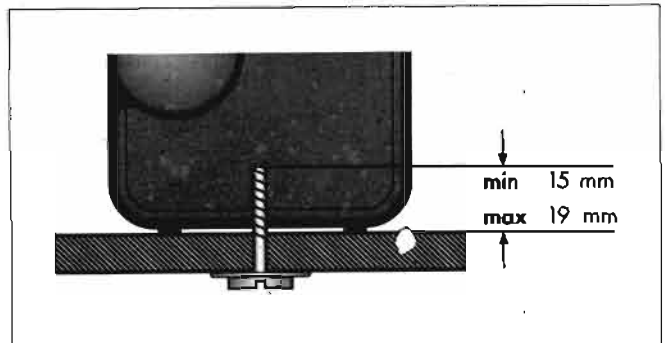

Loudspeaker Socket ①⑮

Contact allocation of the plug for two external loudspeakers.

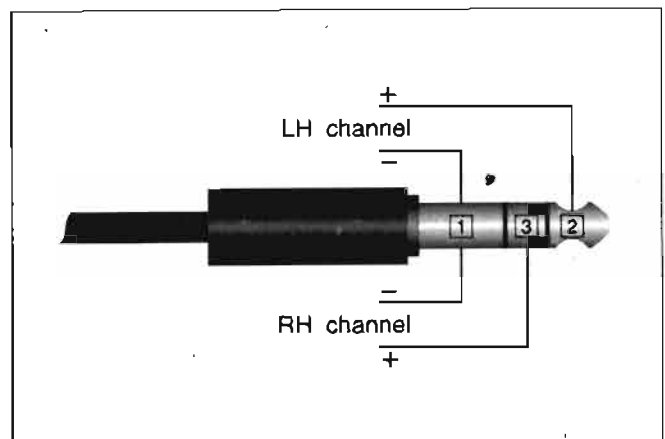

Power Supply

Battery or Accumulator Operation

With 4 "HP2" batteries IECLR20 (alkaline-manganese batteries) or NiCd accumulators of same size (commercially available).

- Only use accumulators with the inscription 1,24 V and 4000 mAh (4 Ah).
- Open the battery compartment 4 (on the back of the set).
- Insert the batteries or accumulators with correct polarity (see scheme on bottom of battery compartment).

Attention!

For battery operation, the slider switch **ACCU/BATT.** (in the battery compartment) must be set to **BATT.**

When batteries are inserted, never set the switch to **ACCU** or leave it in this position (indication 9).

No responsibility can be accepted for damage due to wrong operation of the charging unit.

- When using NiCd accumulators, the switch must be set to **ACCU** (indication 9).

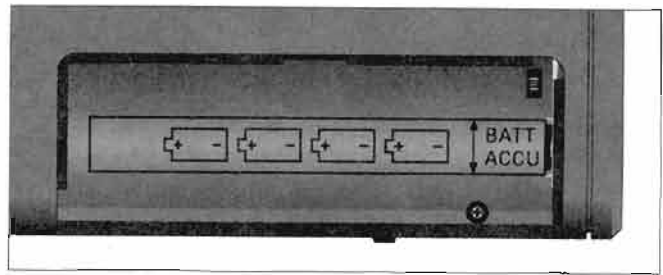

Charging Time

With the AC adaptor NR90, a charging time of up to 4 days will be required, depending on the charging state of the accumulators.

Even if the AC adaptor NR90 remains permanently connected to the unit, the inserted accumulators cannot be overcharged. The adaptor is provided with a safety circuit preventing damage to the accumulators.

Hints

If the set cannot be switched on, or if the frequency indication only briefly flashes after switching on, then the supply voltage is too low. If this should be the case, replace the complete set of batteries or recharge the accumulators.

- Always remove exhausted batteries immediately.
- If the set is not in use for longer periods, remove batteries even if they are new.
- No responsibility can be accepted for damage due to leaking batteries.

Note on Environmental Protection

Do not throw exhausted batteries in the household refuse. Hand over the old batteries to your dealer or a public collecting point when buying new ones.

RESET Button

If, due to external interferences (caused by static charges of carpets, thunderstorms, etc.), the control electronics of the Satellit 700 should receive wrong information signals, or if no entries at all are possible, then press the **RESET** button. This is to be found to the left of the MEMOFILE box 9. For pressing the button, it is best to use a pointed object (e.g., a needle or ball-point pen).

By releasing the **RESET** impulse, the unit is reset to its basic programming values.

The contents of the individual station memory positions are **not** affected.

However, the contents of the **TIME** and switching times memories, set menu options, and the last station memory will be lost.

Data Protection

When the set is switched off, a built-in standby battery (lithium battery, which is automatically recharged when the unit is ready for operation) protects the programmed switch on/off times, the preselected menu options, the last-station-memory, data, and the data stored in the memory positions of the unit. This applies also, when no external DC voltage is connected, or when no batteries are inserted. In this case, the clock continues running, but the clock time is not displayed.

Storage of the data is guaranteed for a duration of 1500 hours.

Caution!

Lithium battery.

Danger of explosion in the case of inexpert handling.

Must only be replaced by an expert technician (as described in the repair instructions).

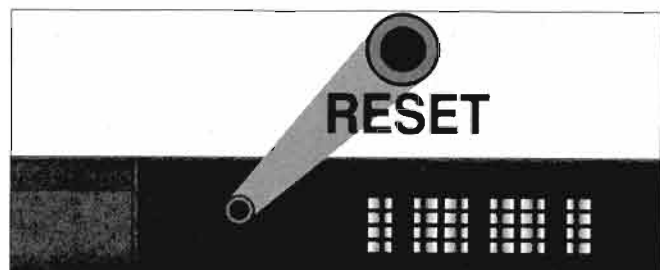

Power Supply

Checking the Condition of the Batteries or Accumulators

After the set is switched on when being operated with batteries or accumulators, the indication **BATT./ACCU** will appear for approx. 10 seconds in the display .

The bar indication above it shows the condition of the batteries or the charging state of the accumulators.

Maximum BATT./ACCU capacity.



Minimum BATT./ACCU capacity.

Change the set of batteries or recharge the accumulators.

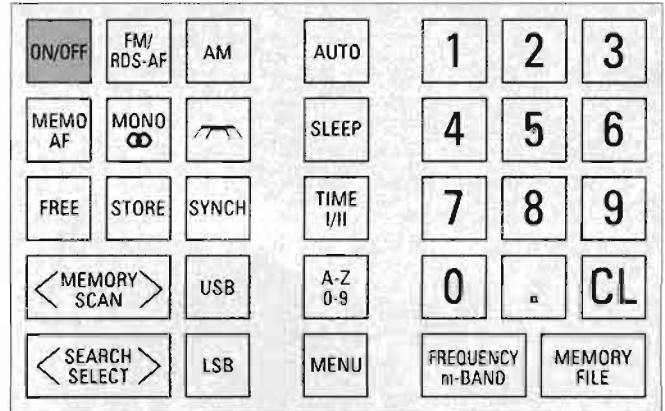

Mains and Charging Operation

With the mains unit NR 90 supplied with the set.

- Adjust the local mains voltage on the mains unit.

220 ... 240V

110 ... 127V

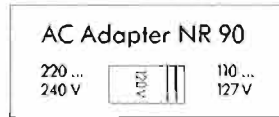

- Connect mains unit to socket **EXT. DC** . Inserted batteries are automatically disconnected as soon as the mains unit is put into operation.

No responsibility can be accepted for damage due to operation with the wrong voltage selected (switch setting).

Remove the batteries if you intend to permanently operate the set on the mains.

Operation on an External DC Voltage

Connect the external DC voltage (9 - 12 V DC from the power supply system of a boat, car or camper) with a commercially available cable (with positive pole inside) to the socket **EXT. DC** .

If you intend to operate the set permanently from the external DC source, then remove the inserted batteries.

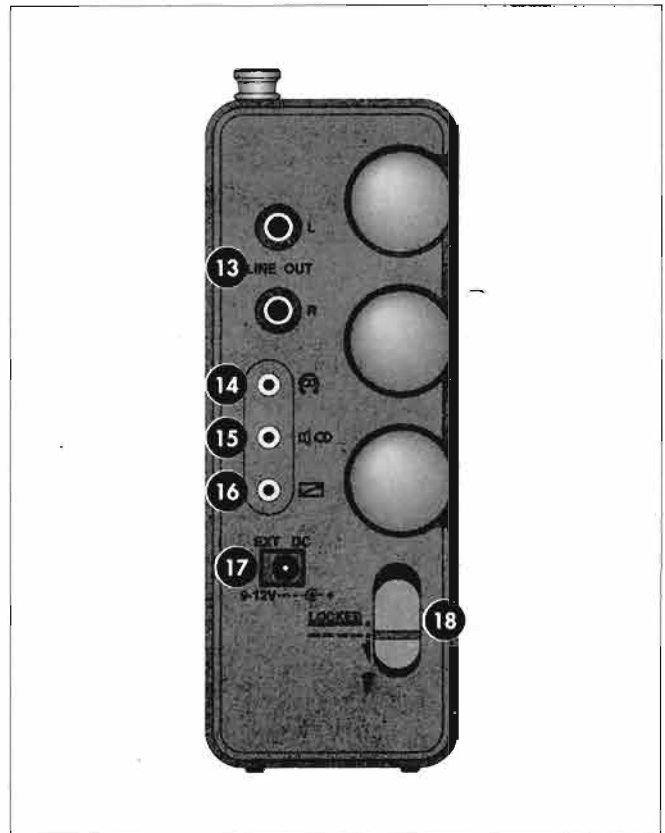

Aerials

for all wavebands

Built-in Aerials for Mobile Operation

- The aerial switch ⑳ must be set to **INT.** (The indication ㉖ must not appear).
- **Telescopic aerial** ⑩ for **FM** and **SW** reception.
- When the aerial base is **completely** pulled out, the telescopic aerial can be tilted and rotated into several locking positions.
- For optimum **FM** reception, do not completely extend the aerial (leave 3 elements pushed in) and swivel it into the best reception position.
- For **SW** reception, fully extend the telescopic aerial and place it vertically.
- **Ferrite rod aerial** for **MW** and **LW** reception.
- Turn the set about its vertical axis to find the best reception position.

Aerial Connection for Stationary Operation with an External Aerial

for all wavebands (FM 75 Ω /AM 50 Ω).

When reception conditions are poor, connect an external aerial system (eg: a common aerial) to the socket **Y EXT** ⑲.

- In this case, the aerial switch ⑳ must be set to **EXT.** (Indication ㉖).

On **AM** reception, the switch **SENS DX/LOC** ㉑ permits to adjust for optimum reception.

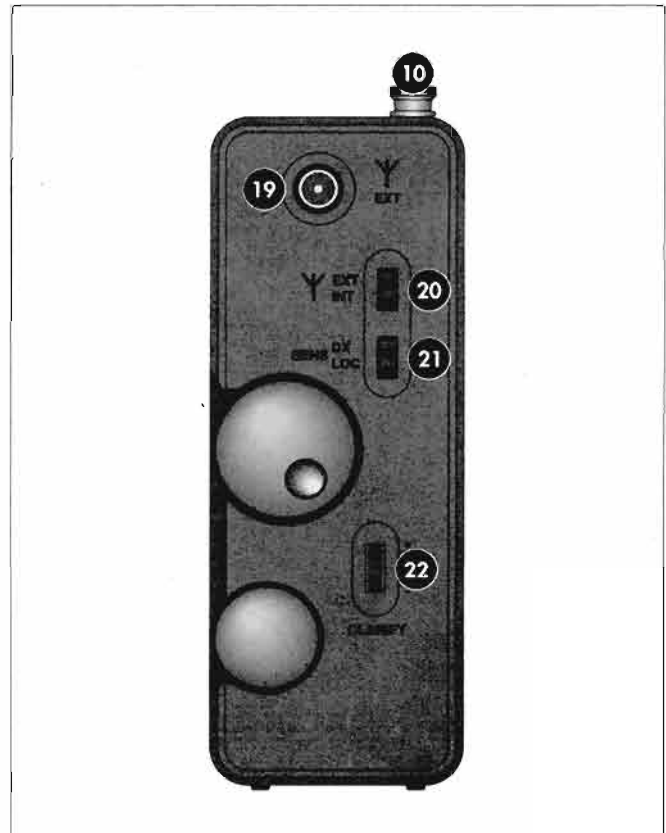











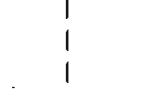

















User Guide Via the Menu

On radio operation, invoke the MENU with the **MENU** button. Use the **<SEARCH SELECT>** rocker button to select one after the other the different menu items (up **SEARCH SELECT >** / **<SEARCH SELECT** down):

TIMER 1 – TIMER 2 – COPY – Display Illumination – Acoustic Acknowledgement – MW Raster Frequency.

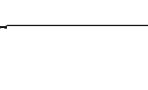
- Exit the user guide via the menu (back to radio mode) with the **MENU** button when **<MENU>** is shown in the display **[1]**.
- When no entries are required (e.g. ON 1, STATION oder OFF 1), you can immediately return to radio mode with the **CL** button (Clear).

Buttons	Display [1]	Remarks
 → 	<MENU>	Activates the user guide via the menu.
 → 	TIMER 1	Invokes TIMER 1 .
 → 	ON 1	Enter switch-on time 1 (see page 59) and confirm by proceeding with the MENU button.
 → 	STATION	Select station memory (e.g. 12 MEMORY) and confirm with MENU button.
 → 	OFF 1	Enter switch-off time 1 and confirm with MENU button.
 → 	TIMER 1	Entry completed.
 → 	TIMER 2	Invokes TIMER 2 .
 → 	ON 2	Some steps as with TIMER 1 .
 → 	• •	• •
 → 	TIMER 2	Entry completed.
 → 	COPY –	Invoke COPY function.
 → 	COPY X	Enter number of MEMOFILE (e.g. 2) from which a copy is to be made onto MEMOFILE 4 , and confirm with MENU button.
 → 	***----	Copying in progress.
 → 	COPY –	Copying completed.
 → 	LAMP ON (OFF)	Display illumination according to state (on or off).
→	LAMP OFF (ON)	Toggling.
→	BEEP ON (OFF)	Beep tone indication according to state (on or off).
→	BEEP OFF (ON)	Toggling.
→	9kHz (10kHz)	MW-raster indication according to state (9kHz or 10kHz).
→	10kHz (9kHz)	Toggling.
→	<MENU>	Exit from the user guide via the menu. After confirmation with the MENU button, return to radio mode.

General Operation of the Set

For convenient operation, the set is provided with a stand (in the back) allowing to bring it in a tilted position.

Hint:

If no time of day is indicated in the display after having applied the voltage supply (mains unit, batteries, accu), then press the **RESET** button.

Cause:

The charge of the built-in rechargeable standby battery (Lithium battery) does not yet suffice.

If this should be the case, maintain the power supply for approx. 24 hours.

See also "RESET Button" on page 40.

Switching On and Off with the ON/OFF Button

Please observe:

To prevent inadvertent operation of the button, its function is activated only when pressing it a longer time.

The locking switch **ⓑ** must **not** be set to **LOCKED**. Otherwise, the set **cannot** be switched on.

Direct Entries

- Enter all numeric values with the **numbered buttons**: Frequencies, station memory positions (programming or calling up), SW-m-bands, times of day, and switching times).

For each entry step, up to **12 seconds** are available. When this time has elapsed, you must repeat the complete entry.

In the menu mode, the set switches approx. 30 seconds after the last entry automatically to radio mode.

- Confirm** the entries with the following buttons: **FREQUENCY/m-Band**, **STORE**, **MEMORY/FILE**, **FREE** and **TIME I/TIME II**.

In the case of wrong entries or misoperation, a comment or an error message appears for approx. 2 seconds in the display **1** after having confirmed the entry (see list below).

In addition, a beep (alarm signal) will sound. The volume is set by positioning the **ⓐ** controller. If you wish to switch off the beep, follow the "User Guide via the Menu" on page 43.



To **immediately** correct wrong entries which are not yet confirmed, press the clear button **CL**.

Indications and Error Messages in the Display **1**

Indications (marked by *)

* NO RDS	The received station is not broadcasting RDS signals or the received RDS signals are too weak.
* RDS - Q	An RDS error rate is shown in the display 23 (see special functions, page 62).
* NO AF	The received station is broadcasting no alternative frequency(ies), or no alternative (optional) frequency(ies) is (are) stored in memory.
* PR - SEL	The individual input tuning circuit function is selected.
* MEMO - -	The actual frequency is already stored in the station's memory - - (actual MEMOFILE).
* NEW	The actual frequency is not yet stored in the actual MEMOFILE.
* FREE - -	The selected station's memory position - - is not occupied.
* FULL - -	All positions of the station's memory are occupied.
* NO MEMO	In the selected MEMOFILE nothing is stored.
* LOCKED	The locking switch is set to "LOCKED".

Error Messages (marked by **)

** FILE	The selected MEMOFILE is not fitted into the unit.
** TIMER	No switching times entered.
** TIME	Times of day or switching times not correctly entered.
** FREQ	Frequency not correctly entered.
** M - BAND	SW-m-band not correctly entered.
** MEMORY	Station's memory position not correctly entered.
** ROM TAB	With the ROM table selected, the buttons "FREE" and "STORE" are without function.

General Operation of the Set

Display Illumination

On battery operation, the illumination can be switched on for approx. 10 seconds by pressing the switch (18) (position ).

When the set is operated (button/tuning knob actions), this time will be prolonged.

On mains operation, the illumination is permanently switched on.

If you wish to switch off the permanent illumination, then follow the "User Guide via the Menu" on page 43.

During mains operation and with the illumination permanently switched off, the temporary illumination functions is possible as during battery operation.

Adjust the Volume and the Tone to Suit Your Taste with the Buttons . . .

① & treble, ② : bass.

Optimum frequency response on FM, MW and LW:
both controls in position "+".

Optimum frequency response on SW:
treble "+", bass "-".

... and the **VOLUME** control (3).

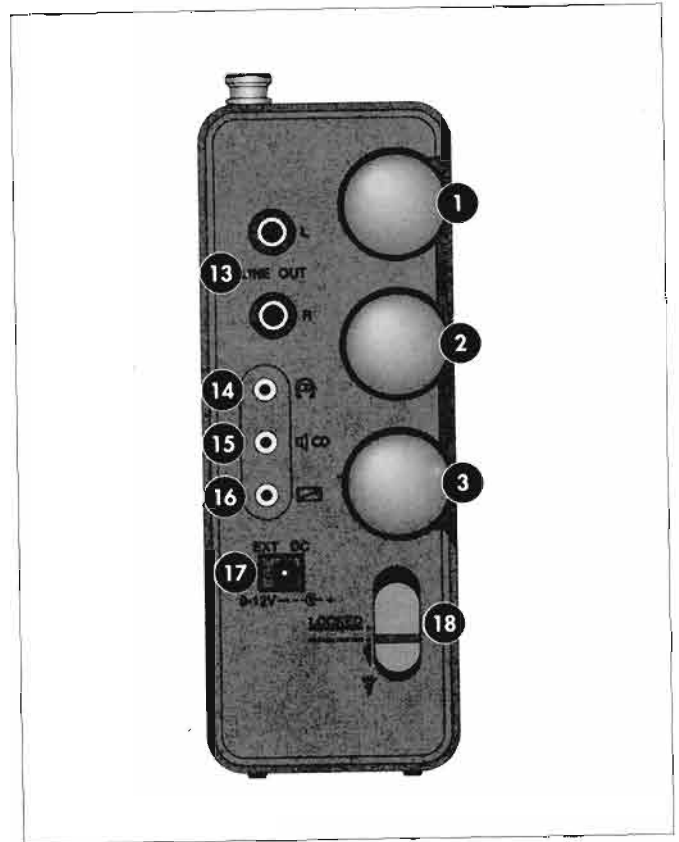

Waveband Selection

When switching on the set with the **ON/OFF** button, the set is ready for reception, and the station tuned to last will be heard.

FM

Select the **FM** band (VHF) with the **FM/RDS-AF** button.

AM

Select the **AM** bands with the **AM** button.

- The first pressure on this button will tune the receiver to the station received last in the respective **AM** band.
- Repeatedly pressing this button steps through the **AM** bands in the following order:

LW → MW → SW → LW → MW → etc.

The station tuned to last in the respective band is heard.

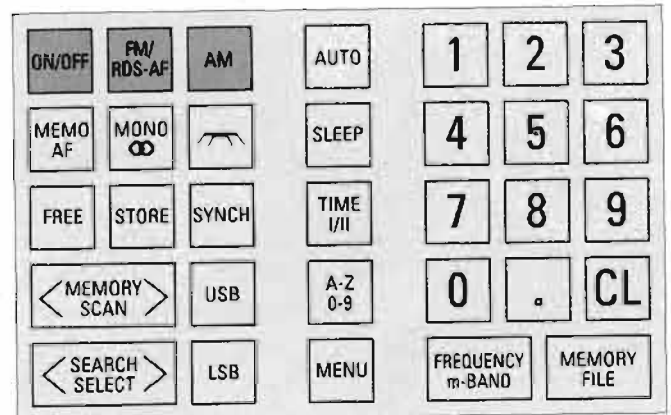

ROM-Table of the Satellit 700

When receiving FM stations which are normally intended for the service of relatively small areas, you can assume an equally good reception quality over the whole day. With some restrictions, this applies also for LW and MW stations during local reception (local stations).

Due to physical laws, in the case of SW reception - mostly used for long distance reception - an equally good reception quality over long periods cannot be achieved. Most of the radio stations operating in the SW range are broadcasting their programmes on several frequencies. By the use of these alternative frequencies on different SW bands, the different propagation conditions during different times of day and seasons are used.

To offer you the most comfortable use of your **GRUNDIG Satellit 700** receiver also during SW reception, this is provided with a ROM table (ROM = READ ONLY MEMORY), in which 96 frequencies* of 9 radio stations operating over the whole world are permanently stored. When receiving such a station, the display of the radio shows the name of the station along with the sign of the country and the frequency tuned to (see frequency card and list).

Selecting Frequencies

For the ROM table, frequencies have been selected which are transmitting in the respective national language, in English, French, and partially also in German.

Despite of the careful selection made with the frequencies, it may happen when selecting a station that . . .

- a) another station is heard than that shown in the display,
- b) only disturbing noise is heard.

The first case is due to the multiple use of individual frequencies.

The second case may have several causes. For example . . .

- that the selected station is currently not broadcasting on the frequency tuned to, or ...
- that the station has currently changed the frequency tuned to with another frequency, or ...
- that the reception conditions are currently very bad for this frequency.

If one of the above cases should happen, it is recommended to call up all alternative frequencies for the station concerned (with the help of the **MEMO-AF** button).

For selecting a frequency, we recommend the following rule of thumb: the brighter the day, the higher the frequency.

For detailed information about the programmes, broadcasting times, frequencies which might have been changed, please consult the radio stations concerned. Addresses can be found on page 66.

With this ROM table, we are sure that you have a means to hand which will help you to inform you about the actually broadcasting radio stations, even if you have no experience in SW reception.

* Especially for the North American area, there are 24 additional frequencies of 13 radio stations stored in the ROM table.

To get access to this part of the ROM table, use the menu item **MW 10 kHz**. (See user guide via the menu on page 43).

Hint

In the USA, it is usual to use the 10 kHz tuning raster.

Extended ROM-Table with 10 kHz-MW-tuning raster especially for the North American area

<u>Code</u>	<u>Station abbreviation</u>	<u>Station</u>	<u>Frequencies (kHz)</u>
0.13	EUROPE	European stations	
		Sweden	11705, 15295
		Greek	9420, 11645
		Spain	9630, 11880
		Vatikan	9605, 11780
0.14	ORIENT	Far East stations	
		South-Korea	9570, 11715
		Australia	9580, 17795
		Taiwan	5950, 9680
		Peking	9690, 11715
0.15	MID EAST	Mid East stations	
		Israel	9435, 11605, 15640
		Egypt	9475
		Turkey	9445
		United Arab Emirates	9600, 15435
		Syria	15095

Selecting the ROM-Table Memory Positions

For selecting stations stored in the ROM-table, you must enter the code number (station code) given in the list or in the frequency card.

This means that you must always enter a zero followed by a dot (e.g., 0.1) before the number and confirm the entry with the button **MEMORY/FILE**.

If you have already selected the ROM table, you may use the button **<MEMORY SCAN>** (press briefly) to select further stations.

Press **>** to go to the next higher station code.

Press **<** to go to the next lower station code.

When pressing the respective button side a longer time, the stations are selected continuously one after the other. In this case, only the first of eight possible alternative frequencies is briefly heard.

Pressing a random button interrupts this station selection mode.

For each radio station, several alternative frequencies are stored in memory. Use the **MEMO-AF** button to select these frequencies.

Each brief pressure on this button selects the next of the eight possible frequencies.

When pressing this button a longer time, the alternative frequencies are selected continuously one after the other and briefly played.

Pressing a random button interrupts this operating mode.

When entering a frequency directly with the numbered buttons (also when changing the waveband) or changing the frequency with the tuning knob, the ROM table is not exited (the indication **23** remains visible).

After having changed the frequency, pressing the button **<MEMORY SCAN>** returns you to the starting point of the ROM table.

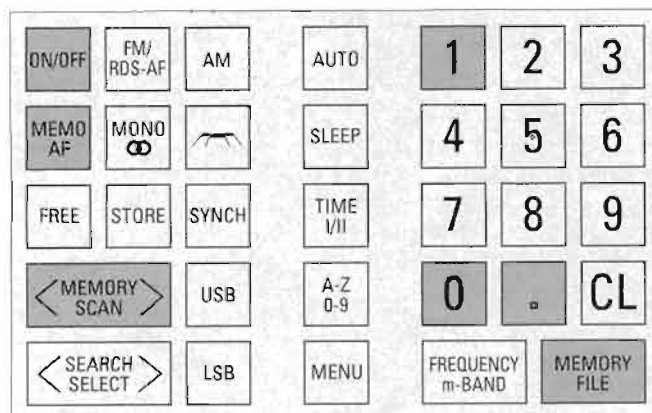

Selecting a MEMOFILE (e.g., 1. **MEMORY/FILE**), exits the ROM table.

Code	Station abbreviation	Station	Frequencies (kHz)
0.1	DW D	Deutsche Welle	3995, 6075, 9545, 9735, 11795, 13780, 15270, 15275
0.2	DW D	Deutsche Welle	15350, 15410, 17845, 17860, 21540, 21560, 21640, 21680
0.3	ROEI . AUT	Radio Österreich International	5945, 6155, 9870, 13730, 15410, 15430, 15450, 21490
0.4	SRI . . SUI	Schweizer Radio International	3985, 6165, 9535, 9885, 11955, 12030, 12035, 15570
0.5	RNED . HOL	Radio Nederland	5955, 6020, 9860, 9895, 13700, 15560, 17575, 17605
0.6	RFI F	Radio France Internationale	3965, 6175, 7135, 7280, 9790, 11705, 15300, 17620
0.7	RAI I	Radiotelevisione Italiana	5990, 6060, 7175, 7275, 7290, 9515, 9575, 9710
0.8	BBC.WS.G	BBC London External Services	3955, 3975, 5975, 6045, 6180, 6195, 7325, 9410
0.9	BBC.WS.G	BBC London External Services	9750, 9760, 9915, 12095, 15070, 17640, 17705, 25750
0.10	RMWS.URS	Radio Moskau	5905, 6145, 7170, 7390, 7440, 9450, 9685, 9765
0.11	RMWS.URS	Radio Moskau	11705, 11995, 12040, 13650, 15465, 17635, 17840, 21450
0.12	NHK J	Radio Japan	11840, 15195, 17765, 17810, 17825, 17890, 21690, 21700

Step by Step into the World of Shortwave Reception

1. Insert batteries or connect the set to the mains.
2. Pull out the telescopic aerial ⑩
3. Switch on the set with the ON/OFF button ⑥ .
4. Adjust to desired volume with the VOLUME button ③ .

For your first experience with SW reception, proceed step by step as follows.

On which frequency you then can receive, for example, BBC London, depends on the time of day. Select "your" frequency (ies) out of the 16 preprogrammed frequencies.

In doing this, please observe:

Besides the indications given in the examples, no further indications should be visible in the display. The time indication (TIME I/II) is without importance in this case.

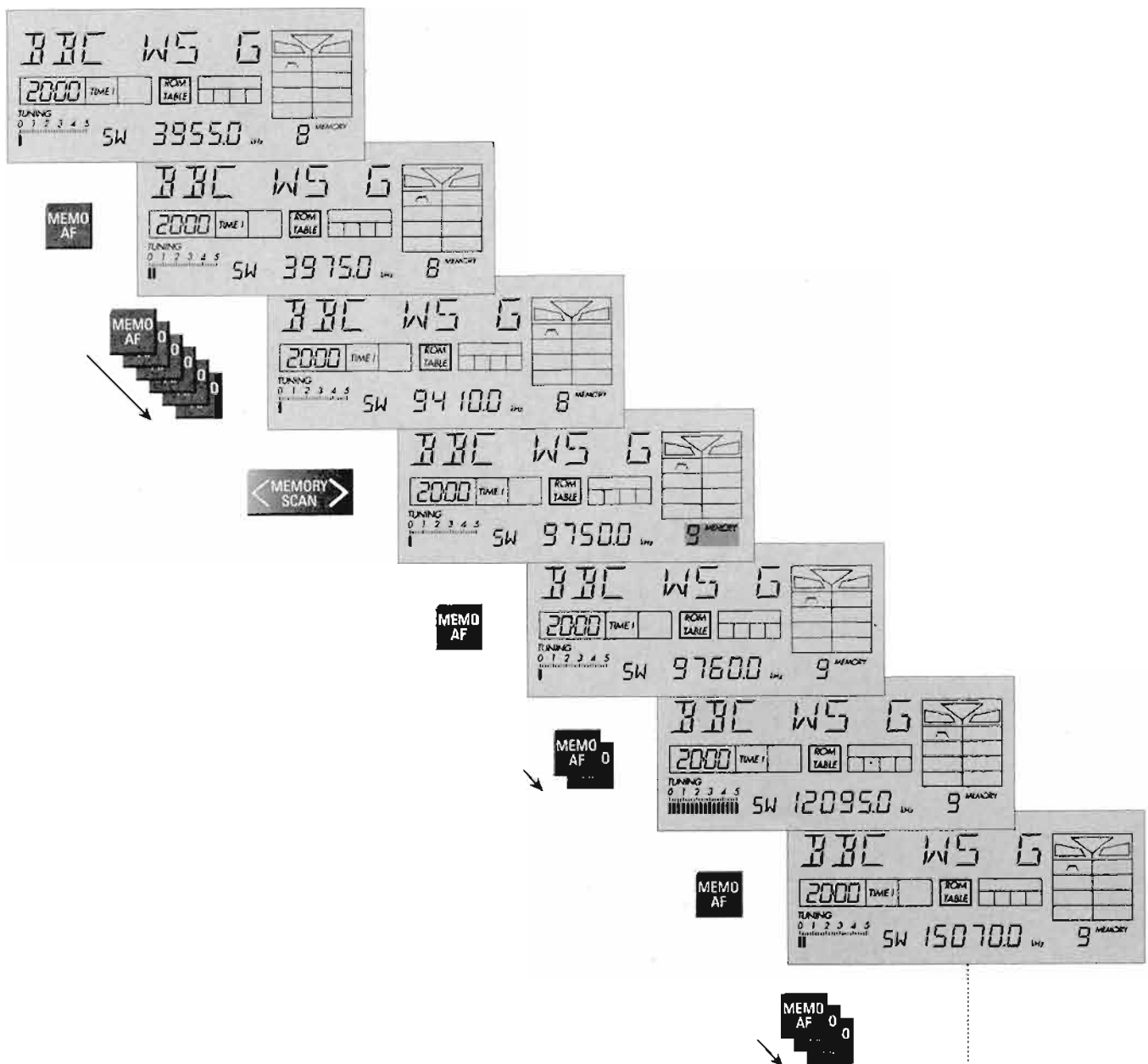

Tuning to Stations Manually or with the numbered buttons

1. Manual Tuning

- Switch on the set with the **ON/OFF** button.
- Select the desired waveband as described under **Waveband Selection**.
- Tune to the desired station with the notched tuning knob **<TUNING>** ⑪.

Each notch of the tuning knob alters the tuning frequency by 1 kHz in the case of **AM** reception (LW, MW, SW), by 100 kHz in the case of **SSB** operation and switch position "SYNCH", and by 25 kHz on **FM** (VHF) reception.

The display shows the frequency tuned to in kHz on **AM**, in MHz on **FM** (VHF), and indicates **HA** in the case of manual tuning. Maximum deflection of the bar indication (TUNING) in the display of the bottom left signals optimum tuning.

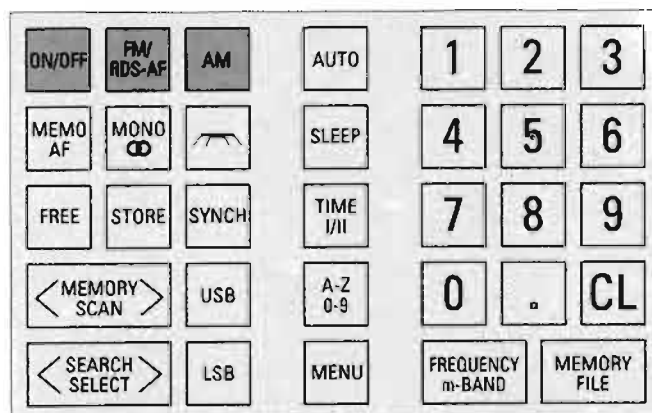

2. Tuning with the Numeric Buttons

(Direct frequency entry)

For this, the frequency of the station to be tuned to must be known.

The frequencies can be found in radio station tables or radio programme guides.

In this case, you need not preselect the required waveband.

On SW, you can also enter a meter band.

You can enter the desired frequency either in **MHz** or **kHz**. Confirm the entries with the button **FREQUENCY/m-BAND**.

On FM: **MHz** indication.

On AM: **kHz** indication.

Examples:

desired frequency	entry sequence
100.100 MHz	100.1 FREQUENCY/m-BAND
100.100 MHz	100100 FREQUENCY/m-BAND
99.000 MHz	99.0 FREQUENCY/m-BAND
99.000 MHz	99. FREQUENCY/m-BAND
88.200 MHz	88.2 FREQUENCY/m-BAND
7000 kHz	7000 FREQUENCY/m-BAND
7000 kHz	7. FREQUENCY/m-BAND
600 kHz	600 FREQUENCY/m-BAND
600 kHz	.6 FREQUENCY/m-BAND

After the frequency entry, the waveband is selected automatically.

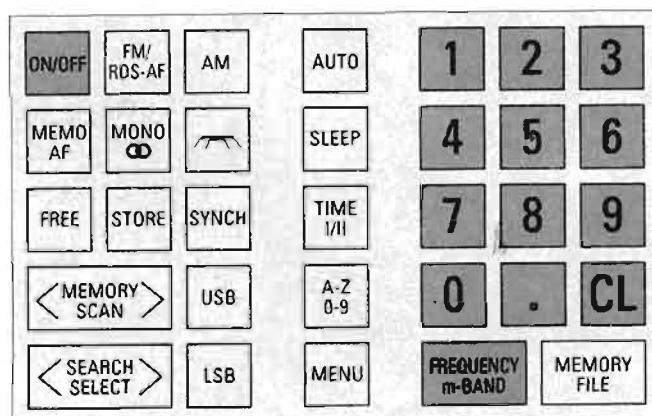

Tuning to Stations with the station search in the FM or AM wavebands

3. Tuning to a Station in the FM Band with the Station Search Rocker Button

- Select the **FM** waveband.
You will hear the station tuned to last in this waveband.
- Start the station search with the rocker button **<SEARCH SELECT>**.
 < = the search starts towards lower frequencies.
 > = the search starts towards higher frequencies.

The station search operates in the 50 kHz raster.

The display **AS** (Auto-Search).

When the automatic station search has found a station with a signal strength sufficient for good reception, it stops.

It can be restarted with the **<SEARCH SELECT>** button.

If the found station is an RDS station, the station name will be displayed after a few moments (see "Special Functions in the FM Wavebands", page 62).

In addition, the indication **HA** (manual tuning) appears in the display **AS**, and the station can be heard.

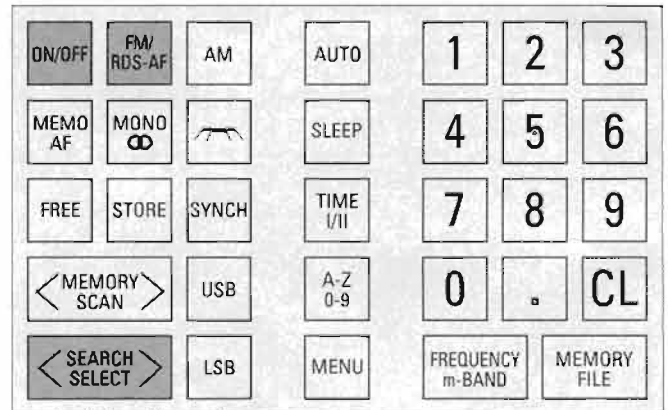

4. Raster Station Search in the AM Band

(Frequency Scanning)

MW (9 kHz and 10 kHz, respectively) and **LW**

By briefly pressing the button **<SEARCH SELECT>**, a frequency already tuned to will be increased or decreased by one raster step. If a frequency lying outside of the frequency raster was selected before pressing the **<SEARCH SELECT>** button, the receiver will automatically tune to the next raster frequency in the selected direction.

Longer pressure on the button (approx. 1 s) will start the **raster search** (frequency scanning) in the selected direction. In this mode, the search will hold for approx. 1 second on each raster frequency and switch to radio play. Pressing any button or turning the tuning knob **Ⓜ** will end this search mode.

SW

Briefly pressing the button **<SEARCH SELECT>** selects the next raster frequency (5 kHz) within a m-band.

< = to lower frequency.

> = to higher frequency.

Longer pressure on the button starts the **frequency scanning** mode in 5 kHz steps within the selected m-band. In the amateur bands, the raster frequency is 1 kHz. When the band end is reached, scanning restarts at the beginning of the same band. Pressing any button or turning the tuning knob **Ⓜ** ends this operating mode.

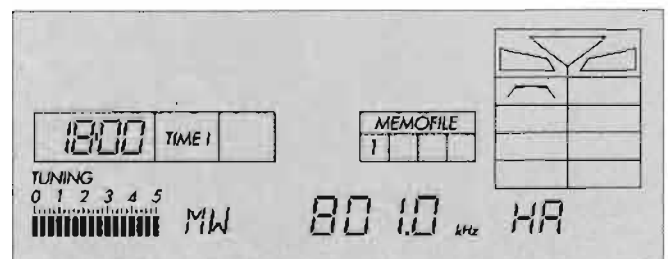

Entering a Meter Band

Entering a m-Band on SW

Entered numbers below 100 with subsequent confirmation by the **FREQUENCY/m-BAND** button will be interpreted as wavelength in meters for SW.

When the entry is correct, the set will tune to a frequency next to the centre of the band in the case of **radio bands**, and to the **beginning** of the respective SW band in the case of **amateur bands**.

See table below.

It is possible to enter the following meter bands:

10, 11, 12, 13, 15, 16, 17, 19, 20, 22, 25, 30, 31, 40, 41, 49, 60, 75, 80, 90.

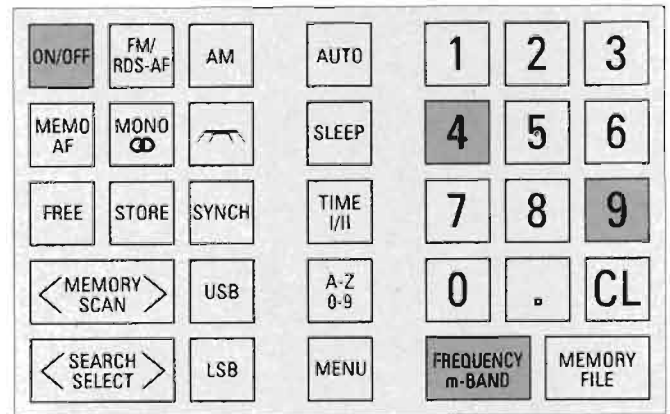

Example for entering the 49-m-Band:

4 9 **FREQUENCY/m-BAND** → 6075 kHz
(= Deutsche Welle).

Indication of the actual meter band on SW

- With direct band entry or in the SW-Raster-Scan mode (within a meter band):
The selected band is permanently indicated.
- With direct frequency entry or manual tuning:
If the frequency tuned to lies in one of the above given meter bands, it will be permanently indicated in the display; if not, the display will show **HA**.
- When calling up a station memory position, the station number indication will be given **priority**.
You can let briefly display the SW-m-band by pressing the **FREQUENCY/m-BAND** button.



Band (m)	Lower Cut-Off frequency (kHz)	Radio Station* or Band Centre
90-m-tropic	3200	3300
80-m-amateur	3500	
75-m-radio	3900	3955 (BBC)
60-m-tropic	4750	4905 (Nairobi)
49-m-radio	5950	6075 (DW)
40-m-amateur	7000	
41-m-radio	7100	7220 (Budapest)
31-m-radio	9500	9635 (BBC/Monaco)
30-m-amateur	10100	
25-m-radio	11650	11845 (BBC)
22-m-radio	13600	13700
20-m-amateur	14000	
19-m-radio	15100	15320
16-m-radio	17550	17705 (BBC)
17-m-amateur	18065	
15-m-amateur	21000	
13-m-radio	21450	21690 (DW)
12-m-amateur	24890	
11-m-radio	25650	25820 (France)
10-m-amateur	28000	

* Not all radio stations are transmitting broadcasts all day and night long, and during all seasons. For this reason, please observe the different transmitting times.

Storing Stations General

Memory Configuration

With the standard version of the Satellit 700 equipped with one MEMOFILE, up to 64 station memory positions with 8 alternative frequencies each (= 512 alternative frequencies) can be programmed in random order – also mixed out of the 4 wavebands FM – MW – LW – SW.

In the Memofile box ⑨, three receptacles for plugging in further MEMOFILE modules for $64 \times 8 = 512$ frequencies each are provided.

Thus, when fully equipped, $4 \times 64 \times 8 = 2048$ alternative frequencies are available.

However, the description in the following chapters is confined to the standard version of the Satellit. How to use the additional Memofiles is described on page 65.

What can You Store ?

Each station you are currently listening to can be stored in memory.

The associated operating modes (mono/stereo, AM bandwidth, LSB/USB, Synch) are automatically stored along with the stations.

On each station memory position, you can store in addition an alphanumeric abbreviation (e.g., name, collective term, or something like that) of up to 8 positions – even at a later date.

When receiving an RDS station on the FM band, the station name is automatically displayed and transferred into the respective station memory position when storing this station the first time.

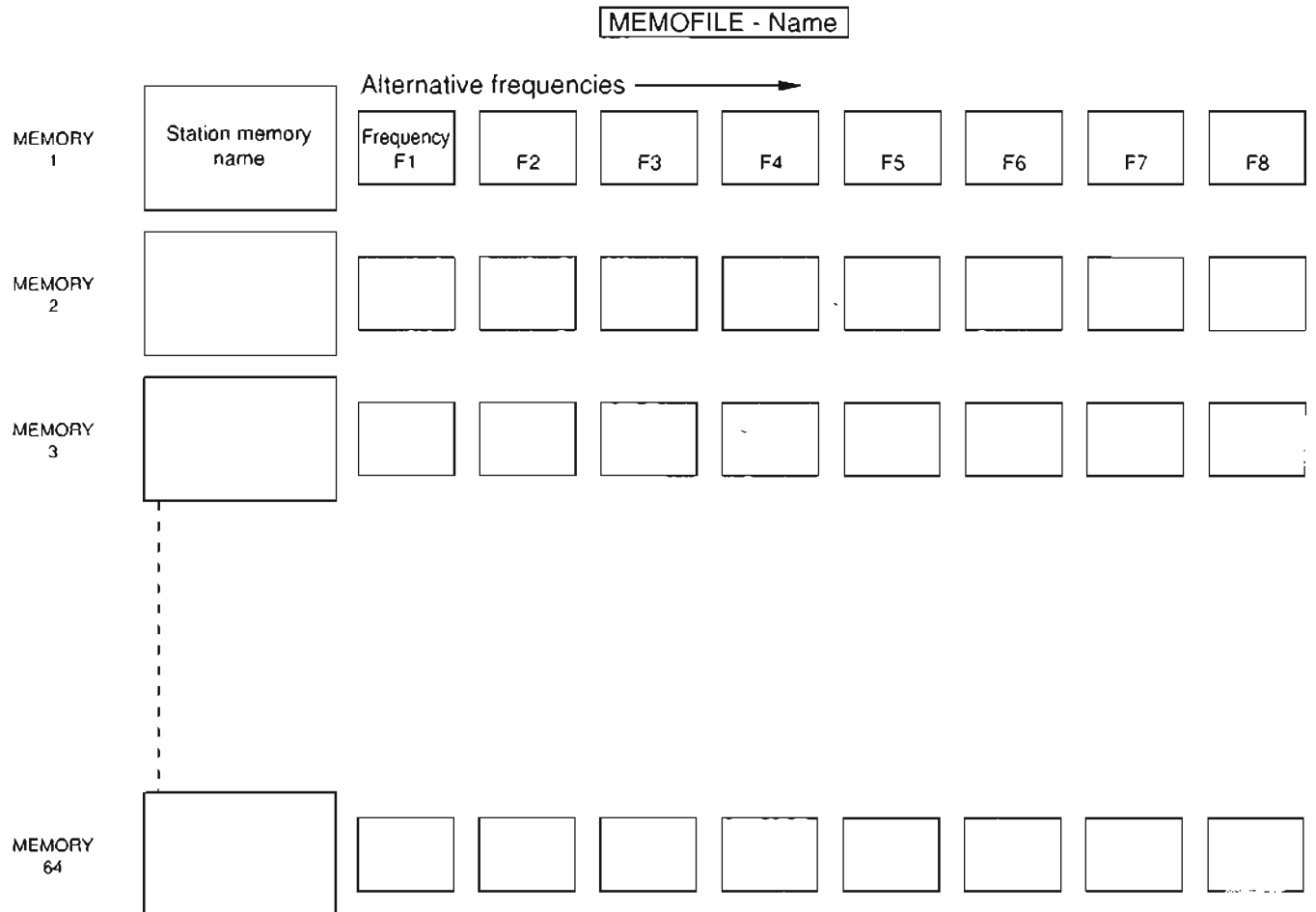

Storing Stations Preparations

The frequency tuned to, is it already stored in memory?

- Before storing a station, you can check whether it is already stored in the actual MEMOFILE by briefly pressing the button **STORE** (Store Compare). If the station is already stored, the station number (e.g., *MEMO 12) will appear in the display.
- By holding down the button, you can check whether the station is already stored several times and – if so – on which station positions.

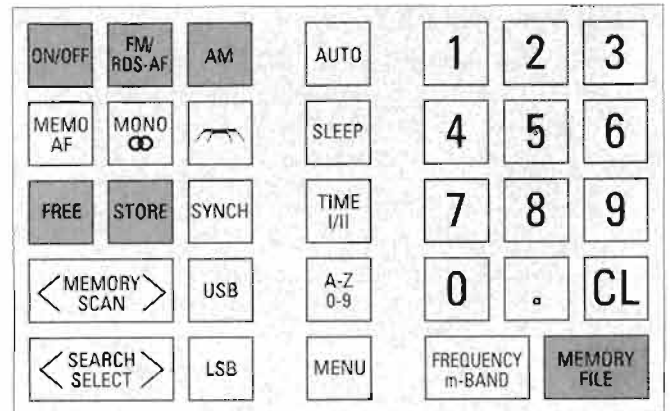

If the station is not yet stored, the display will show *NEW. Because of the large capacity of the memory, this indication appears only after approx. 1 second.

The store compare function is only executed in the currently active MEMOFILE.



Checking the Intended Station Memory Position

To avoid that an already stored station be accidentally erased, you can select it for a check before storing the new station. When doing this, the station intended for storing is temporarily stored in the manual tuning memory (HA in the display):

- Enter the number of the station memory position with the numbered buttons.
- Press button **MEMORY/FILE**. If the memory position is free, the display will show *FREE; if a station is already programmed, the display will show the frequency of this station. During this function, the station tuned to last in the respective waveband remains always temporarily stored on the numbered button "0".

Before you can retrieve this station, it may thus be necessary to first select the respective waveband by pressing the **AM** button several times or switching to **FM**. Then retrieve the station by pressing the numbered button "0" and then the button **MEMORY/FILE**, and search another station memory position.



Searching Free Station Memory Positions

The button **FREE** offers a further possibility of searching free memory positions. As long as you are pressing down the **FREE** button, the numbers of the free memory positions are shown one after the other beside the indication *FREE in the display. If all memory positions are already occupied, the display will show *FULL.



Storing and Calling Up Stations Clearing a station position

Initial Memory Allocation

(In this case, the whole stations memory is overwritten):

- Enter the number of the memory position with the numbered buttons.
- Press button **STORE** a longer time.
As confirmation, the display **3** will briefly show *MEMO and the number of the selected memory position. The stored station is still heard.

An entered name or decoded name of an RDS station – also visible in the display – is stored along with the radio station.

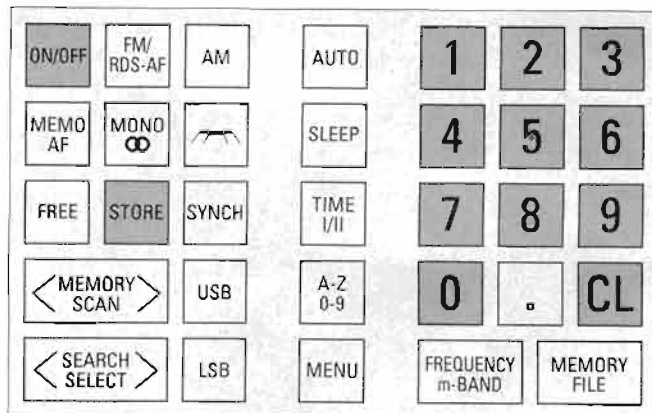

Calling Up Stored Stations

- Enter the number of the desired memory position with the numbered buttons.
- Press the button **MEMORY/FILE**.
– If the selected memory position is not occupied by a station, the display will show *FREE for approx. 3 seconds. The station tuned to before will further be heard.

When calling up stored stations with the numbered buttons, the unit automatically selects the correct waveband (Intermix function).

The unit always selects the first occupied alternative frequency memory position.



Button <MEMORY SCAN>

With this button, you can call up occupied station memory positions one after the other:

- < = in direction of descending memory position numbers.
- > = in direction of ascending memory position numbers.

The unit calls up the next possible memory position. In the display appears the first occupied alternative frequency position and the station name, provided this has been entered or is received via the RDS system.

Memory positions which are not occupied are automatically skipped.

Longer pressing the button (approx. 1 s) starts the memory search in the desired direction. In this case, each stored station will briefly be played and the name displayed (if it is also stored).

Pressing any button or turning the tuning knob (i) will end this function.

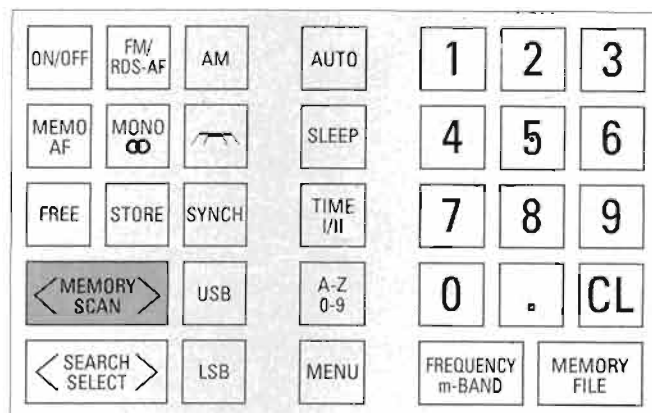

Clearing an Occupied Memory Position

- Enter the number of the desired memory position with the numbered buttons.
- Press button **FREE** a longer time.
The display will show *FREE and the number of the memory position (station number).
In doing this, the complete stations memory is cleared.



Storing Stations Adding abbreviations

Entering Abbreviations

(e.g., station name)

On each station memory position (1 – 64 with the standard version of the Satellit), you can programme a name for the station (8 positions max.) along with the station frequency, for example, WARSAW, HELSINKI, BUDAPEST, etc., which is then shown in the display **1**. This can be done when storing the frequency, or at a later date.

- The entry is initialized with the button **A-Z/0-9**.
The station tuned to will further be heard and a cursor will flash at the left in the display **1**.
- By turning the tuning knob **11**, you can select a letter (A-Z), a figure (0-9), and several special characters.
A blank can be found between **A** and **9** (cursor character).
- Each pressure on the button **SEARCH SELECT** moves the cursor one position to the right for entering the next position (to the left with the button **<SEARCH SELECT**).
- After having entered the last position, again press the button **A-Z/0-9**. The cursor will disappear and the entry is allocated to the station memory position.
- When pressing the **A-Z/0-9** button once more, the cursor will appear again on the left side, thus allowing correction of wrong entries.

When quitting the entry mode (e.g., by selecting another function), the entries made up to this point are automatically stored into memory.

Quitting the entry mode with the **CL** button:

The entry made is **not** stored in memory.

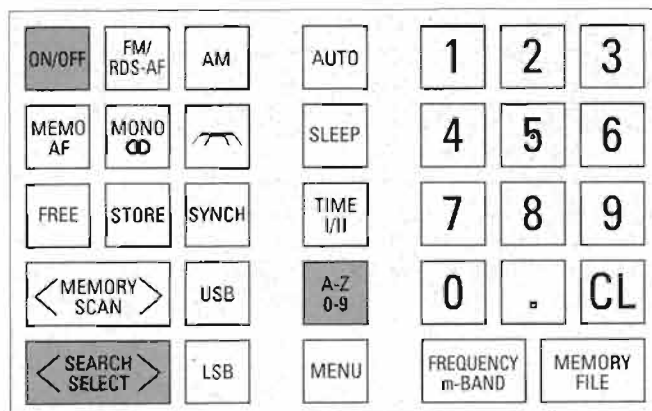

Storing a Name for the MEMOFILE

(In the example, the name EUROPE is to be allocated the MEMOFILE 1).

- The station tuned to must not be an RDS station (nothing in the display **1**). It is therefore recommended to perform this storage allocation in one of the AM bands.
- Press the button **A-Z/0-9** – the cursor flashes at the left in the display **1**.
- You can select a letter (A-Z) or a figure (0-9) with the tuning knob **11**. A blank can be found between **A** and **9**.
- Press the button **SEARCH SELECT** to move the cursor one position to the right for entering the next position.
- After having entered the last position, again press the button **A-Z/0-9** – the cursor disappears.
- Now press the buttons **1 .** and then the button **STORE**.
The entered name is stored in memory.

Displaying the Name of a MEMOFILE

- No entered number must be shown in the display **16**, as this would be interpreted as a station call-up.
- Press the button **MEMORY FILE** a longer time.
As long as you press and hold this button, the name of the current MEMOFILE – EUROPE in our example – will be displayed.

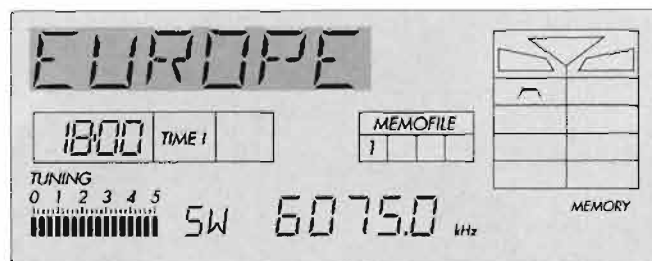
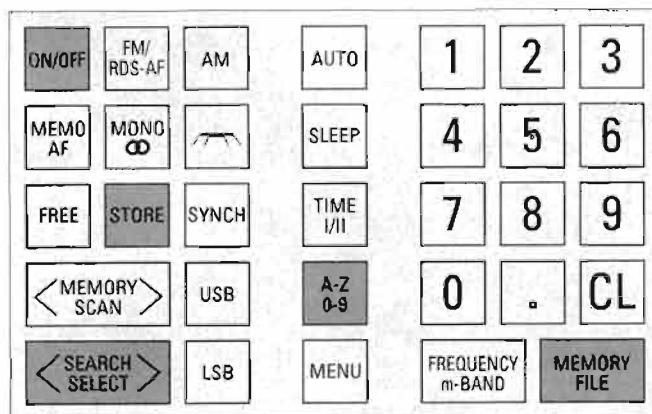

Storing and Calling Up Stations Storing alternative frequencies

Creating a Stations Memory

(see also under "Initial memory allocation")

- Tune to the desired radio station.
- Select the desired station memory position with the numbered buttons (e.g., 42).
- Press the button STORE a longer time.
- The old contents of the memory position are cleared and the first frequency memory position is allocated the frequency tuned to, and – if a name is displayed – this name.

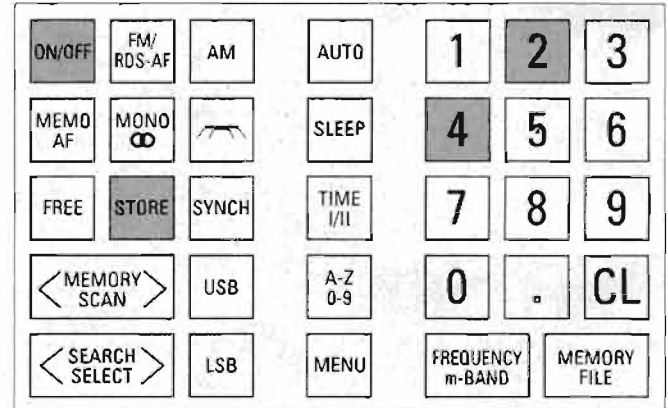

Calling Up a Station Memory Position

- Select the desired station memory position with the numbered buttons.
- Press the button MEMORY FILE. The first possible alternative frequency will always be selected.



Storing Alternative Frequencies in Memory

- Tuning to alternative frequencies
 - with RDS stations with the button FM/RDS-AF,
 - with AM and non-RDS stations by hand.
- Select the desired station memory position with the numbered buttons (e.g. 5).
- Briefly press the button STORE.
 - You can also press the FREE button instead of the STORE button in this case, as the real function (store/clear) will be selected later.

The display **1** will show, for example:

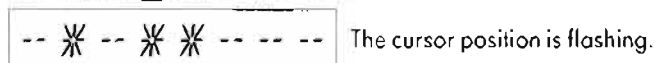

In our example, the display shows that the frequency memory positions F 2, F 4, and F 5 are allocated. The frequency you wish to store in memory is still to be heard. However, shown is the frequency marked by the cursor, or the indication "-----" when the selected frequency memory position is free (indication **18**).

Use the button <SEARCH SELECT> to move the cursor to an appropriate (free) frequency memory position. When now pressing the STORE button, the frequency tuned to is stored in memory and the selected frequency memory position becomes the actual position.

- Press the CL button to end this function.

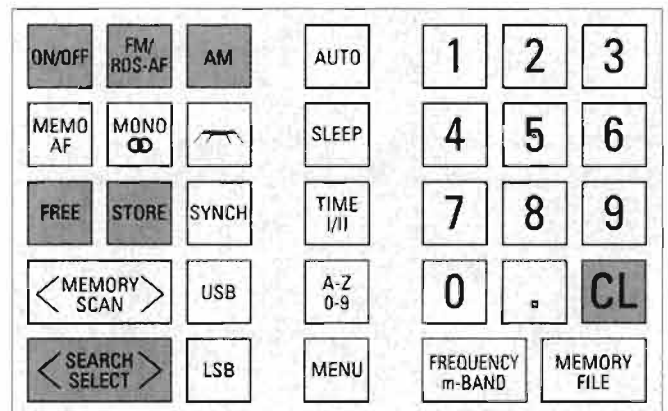

Storing and Calling Up Stations Calling up/clearing alternative frequencies

Calling Up Alternative Frequencies

For this, it is assumed that you have already selected a station memory position.

- Pressing the **MEMO-AF** button displays the alternative frequencies of one station memory position one after the other in one direction.
First, the display shows the name of the respective station memory position, and a few moments later the station name broadcasted by the RDS station when such a station is received. Free frequency memory positions are skipped. If only one frequency position of a station memory position is allocated to a frequency, the message *NO AF appears.
- When you press and hold the **MEMO-AF** button a longer time, each available alternative frequency will be played for 3 seconds, until you cancel this function by pressing any button.

Example

Selecting the third allocated alternative frequency memory position (F 7 in our example) of a station memory position with the following internal structure (display 1):

Name	--	F2	--	--	--	F6	F7	F8
------	----	----	----	----	----	----	----	----

The indication "--" means "free".

When calling up the station memory position, F 2 will be played first.

- Press button **MEMO-AF** – F 6 is playing.
- Press button **MEMO-AF** – F 7 is playing.
- Press button **MEMO-AF** – F 8 is playing.
- Press button **MEMO-AF** – F 2 is playing, etc.

Going to Sleep to Radio

The **SLEEP** button permits to programme a playing time ("sleep time") of up to 60 minutes.

- Repeatedly pressing the **SLEEP** button increases the playing time in 10-minute steps up to 60 minutes max.
Indication: 10, 20, 30, 40, 50, 60, 0, 10, 20 etc.
- Longer pressing the **SLEEP** button automatically increases the playing time in steps of 10 minutes.
 - The display 17 shows **SLEEP**, and the display 21 shows the currently entered playing time.
 - When the programmed sleep time has elapsed, the radio switches off automatically, and the indication **SLEEP** disappears.

Checking the playing (sleep) time:

- Briefly press the button **SLEEP**.
The display 21 shows the time remaining till the automatic switch-off.

Premature erasure of the switch-on time:

- Switch the unit off with the **ON/OFF** button.

Clearing Alternative Frequencies

- Proceed in the same way as for storing, but enter **FREE** instead of **STORE**. It does not matter with which button (**STORE** or **FREE**) the menu has been invoked. Both functions are always possible.

Example

You wish to clear the fourth allocated alternative frequency position (F 8) of the station memory position "5":

- Press the numbered button "5" and then briefly press the button **FREE** or **STORE**.
- Use the button **<SEARCH SELECT>** to move the cursor to "F 8".
- Press button **FREE** to complete clearing.
The selected alternative frequency is cleared.

MEMO	--	F2	--	--	--	F6	F7	F8
5								

MEMO	--	F2	--	--	--	F6	F7	--
5								

- When clearing the frequency currently tuned to, this will be stored in the tuning knob memory.

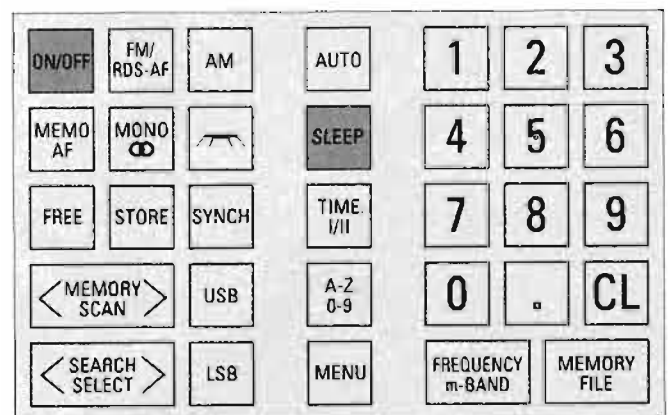

The Clock

- The period of approx. 12 seconds available for each entry applies also for the clock.
- You can enter times no matter whether the unit is switched on or off.
- Times of day and switching times can be entered in several different ways.

Examples:

Time of day	Entry sequence
1st example: 6.30 hours	630 0630 6.30 06.30
2nd example: 15.00 hours	15 1500 15.
3rd example: 0.15 hours	.15 015 0015

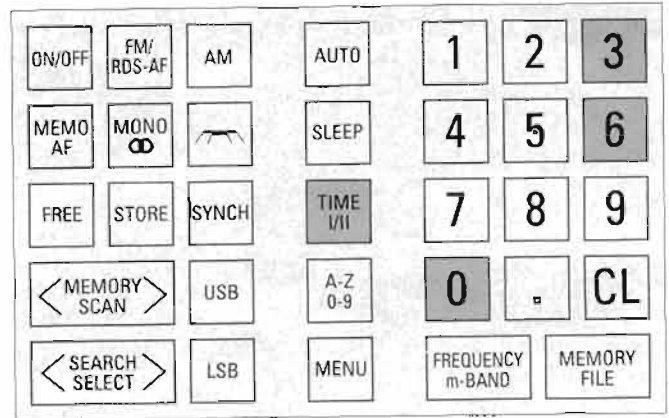

Setting the Clock

(TIME I/Time of Day I) with the help of a reference clock.

Example TIME I: 6.30 hours:

- The display **22** must show **TIME I**.
- Enter the time with the numbered buttons.
- Press and hold down button **TIME I/II** until the reference clock changes from 6.29.59 to 6.30.00.
- When releasing the button **TIME I/II**, the clock starts running to the second and the colon between the hours and seconds indication is flashing.
- The set time is now shown in the display **6:30**.



Setting the Clock

(TIME II/Time of Day II) with the help of a reference clock.

For programming **TIME II/Time of Day II**, proceed in the same way, with the only difference that the display **22** must show **TIME II**.

As the seconds of **time II** are running synchronously with the seconds of **time I**, you need not wait till the minutes change in this case.

Time Indication TIME I/II

- You can switch over (toggle) between the two times by repeatedly pressing the button **TIME I/II** (without entering a number).



Automatic Functions Timer 1

You can enter two independent switch-on and switch-off times.

Each switch-on time can be allocated to a different station. You can, for example, let automatically switch on your favorite station by the switch-on time 1.

If there is another programme (eg: latest news) broadcasted on the same station or on another waveband that you wish to listen to when the set has been switched on by the switching time 1, select this programme with switch-on time 2 and switch-off time 2.

You then will hear this programme during the selected time intervall as soon as switch-on time 2 is reached. After that, the unit will be switched back again to the switching times 1.

Please note . . .

when both switching times are programmed and overlap each other, then:

- Switch-on times always have priority over switch-off times.
- The second switching times have priority over the first switching times.

Already programmed stations are not affected by time programming.

The switching times refer to the times (TIME I or TIME II) shown in the display.

An example for better understanding:

You have programmed the local time (eg: MEZ or MESZ) as TIME I.

TIME II stands for a second time zone (eg: Universal Time/UTC).

You have programmed 14.00 hours as switch-on time and switched the radio to "AUTO".

If now the display shows TIME I, the set will be switched on at 14.00 hours local time.

If the display shows TIME II, the set will be switched on at 14.00 hours of the second time zone.

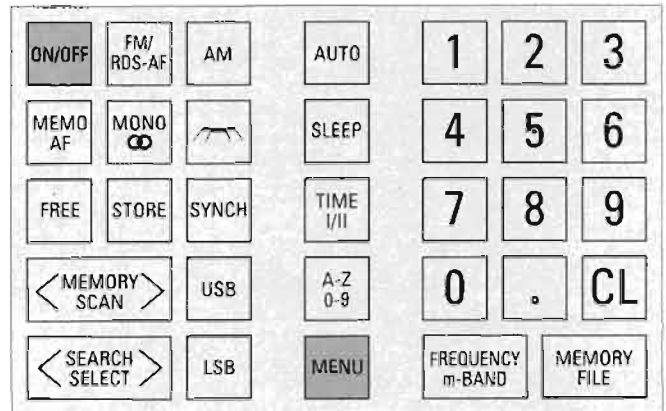

Programming Switching Times

Switching Times 1

- Switch on the set.
- Select the menu item **TIMER 1** according to the "User Guide via the MENU" (page 43) and activate the function by pressing the **MENU** button.
 - The display **1** shows **ON 1**.

The display **16** shows -- : -- if no time has already been entered, or the switch-on time entered last.

- In the second case, simply "overwrite" the existing entry.
- Enter the desired switch-on time with the buttons 0 - 9/, and confirm with the **MENU** button.
 - The display **1** shows **STATION**.
- Select the desired station with the button **<MEMORY SCAN>** or with the buttons 0 - 9/, and **MEMORY/FILE**, and enter an alternative frequency - if desired - with the button **MEMO-AF**.
- Confirm the entry with the **MENU** button.
 - The display **1** shows **OFF 1**.

The display **16** shows -- : -- if no time has already been entered, or the switch-off time entered last.

- Enter the desired switch-off time with the button 0 - 9/, and confirm with the **MENU** button.

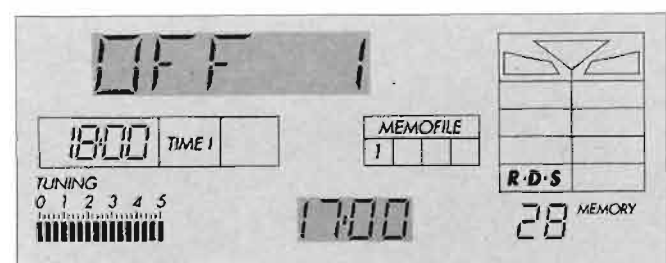
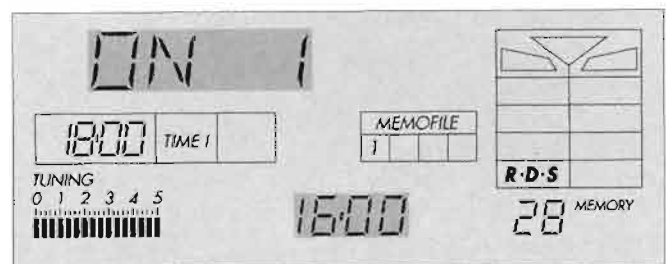

Automatic Functions Timer 2, clearing and activating

- The switching times for **TIMER 1** now are stored in memory and the menu item **TIMER 1** is shown again. You hear the station tuned to last.
- Now you can select the second menu item (**TIMER 2**) with the button **<SEARCH SELECT>** , or check the **TIMER 1** settings by repeatedly pressing the **MENU** button.



Switching Times 2

- Switch on the set.
- Select the menu item **TIMER 2**.
- Continue as for the switching times 1.

Checking the Switching Times

- Repeatedly pressing the **MENU**-button with the menu item **TIMER 1** or **TIMER 2** selected, will show one after the other the switch-on time, the station, and the switch-off time

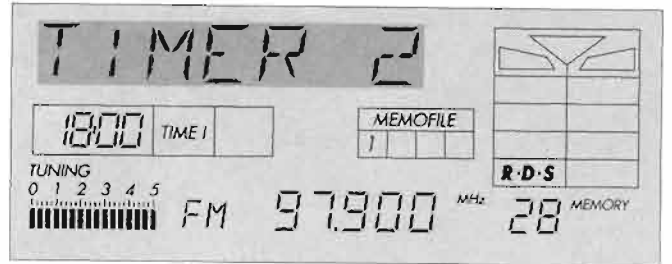

Clearing Switch-On Times

This function can be used, for example, if you wish to "lock" one of the two switch-on times.

To do this, simply enter no switch-on time or clear an existing entry with the **CL** button (after selection of **ON 1** and **ON 2**, respectively).

The display **16** will show **--:--**.

- Switch back to radio operation by pressing the **MENU** button with the **<MENU>** item selected. The selected station number (memory position) and the programmed switch-off time are conserved.

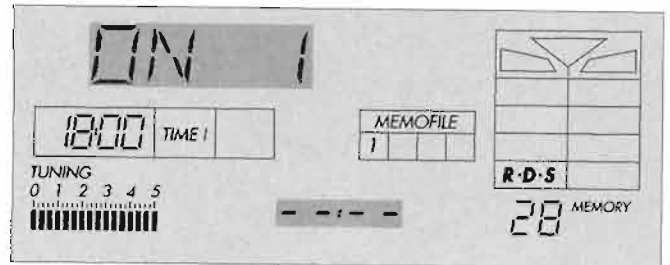

Automatic Switching On and Off

- The automatic functions can be switched on and off with the **AUTO** button.
- So that the automatic functions are executed, **AUTO** must be shown in the display **19**.
- The switching times must be programmed.
- The set must be tuned to the desired station and set to the required volume level. Then:
 - Press the **AUTO** button.
 - The set is switched off and the following indications are shown:
 - Time of day (display **21**)
 - TIME 1** or **TIME 2** (display **22**)
 - AUTO** (display **19**)
 - Switch-on time (display **16**)

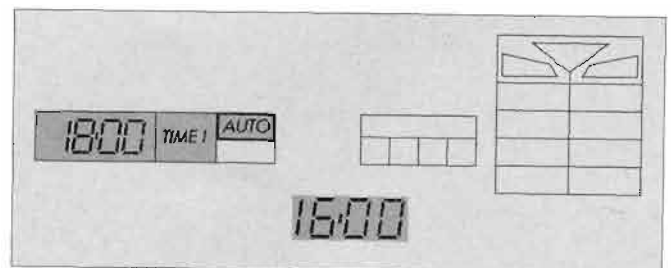

- If not at least one switch-on time has been entered, a comment along with the error message ****TIMER** will be displayed when pressing the **AUTO** button.
- Of course you now can switch on and off the set with the **ON/OFF** button to listen to the radio independently of the programmed switching times.



Automatic Functions Timer recordings

- If two switching times are programmed, the display 16 will show the next switch-on time. When the preceding switching time has elapsed, the display is switched to the next switch-on time.

At the programmed times, the set is automatically switched on and off.

Clearing the Switching Times

To do this, press the **AUTO** button until the indication **AUTO** disappears from the display 19.

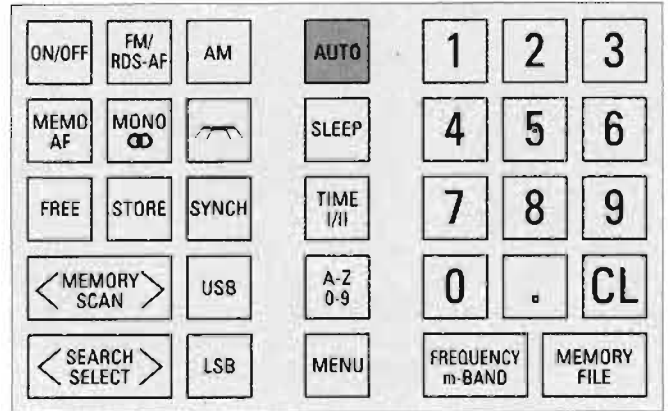

Timer Recordings

If you have a cassette recorder with **start/stop remote control facility**, you can record radio programmes between the programmed switching times.

To do this:

- Connect the output switch jack 16 with the switch jack of the cassette recorder.

Technical details are given to the right.

Automatic Control of a Cassette Recorder

With the timer built into your Satellit 700, it is possible to automatically start and stop a cassette recorder which is equipped with a positive or negative control logic circuit.

For this, you will require a special connecting lead.

Please consult your specialized dealer.

For **stereo recordings**, connect both **LINE OUT** sockets 13 of the Satellit 700 with the **LINE IN** sockets of the cassette recorder, observing correct **channel allocation**.

For **mono recordings**, the connection of one **LINE OUT** socket 13 of the Satellit with the **LINE IN** socket of the cassette recorder will suffice.

For recording stereo broadcast in this case, switch the Satellit to **MONO** mode (**MONO** button 6).

- Switch the cassette recorder to recording-start. When the Satellit is automatically switched on, the cassette recorder is started too and records the programme of the station tuned to.

Hint for the specialized dealer

In the automatic mode, the switching voltage delivered by the cassette recorder (max. 30 V, 500 mA) is changed as follows:

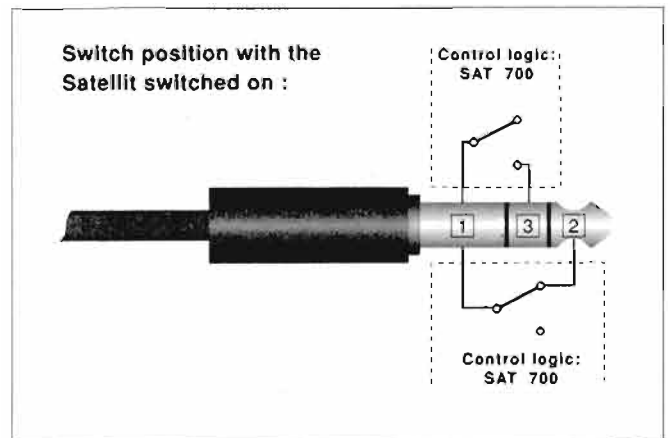

The switching circuit for controlling the cassette recorder operates "potential-free" (relay control).

Special Functions on FM

RDS (Radio Data System)

RDS is a digital information system, the signals of which are broadcasted together with the FM radio programme.

Your unit is equipped for operation with this information system. It evaluates the codes for programme identification (PI), Programme service (PS), and the alternative frequencies (AF).

This permits to indicate the name of the stations chain and to compare the signal strength of different stations broadcasting the same programme.

So that the radio can decode the RDS signals, the reception quality must be sufficiently good. This applies especially for operation with the telescopic aerial.

This means that the reading on the TUNING meter 20 must show its full deflection when receiving an RDS station. A further condition is the appearance of the RDS symbol in the display 12.

When these two conditions are met, the name of the stations chain will be shown for approx. 10 seconds. If this is not the case, decoding of the RDS signals is probably disturbed by multiple reception (reflections).

In most cases, this is **not** shown by a changing field strength indication on the TUNING meter 20. However, the indication of the RDS symbol in the display 12 may be unstable in this case. This is known under the special phrase

too great RDS error rate.

By the special function RDS - Q (= RDS quality),

indication in the display 5: *RDS - Q,

the TUNING (field strength) indication 20 is switched over to the RDS error rate indication.

If all 16 segments of this display are visible, this means an error rate of 0%. The illumination of 8 segments thus means an error rate of 50%.

To switch on this function, permanently press and hold the button  (bandwidth).

If the name of the stations chain does not appear within the time stated above, then press and hold pressed the bandwidth button and simultaneously rotate and tilt the telescopic aerial to minimize the RDS error rate. This means that the display 20 must show as many segments as possible.

Especially when operated in a building, the location of the unit can be essential for good RDS reception.

If required, try to operate the unit at different locations until you obtain good RDS reception.

Please note:

Indication of the RDS error rate is only possible together with the indication of the RDS symbol 12.



Calling Up Alternative Frequencies (AF)

If the RDS symbol appears in the display 12 and the name of the stations chain (stations broadcasting the same programme) is shown, then it is possible to call up the alternative frequencies of the stations chain.

This is done by pressing the button FM/RDS-AF. During this function, the indication AF 11 appears in the display 5.

When the frequencies are called up, the unit checks their field strength.

If the found field strength suffices for RDS reception, calling up of the frequencies is stopped. The found frequency is shown and the muting function which has been switched on at the beginning of the checking function is switched off again.

If no alternative frequency with sufficient field strength is found, the unit tunes again to the initial frequency.

Hint

Shortly pressing the button FM/RDS-AF = the alternative frequencies are shown in the direction of increasing frequencies.

Longer pressing the button FM/RDS-AF = the alternative frequencies are shown in the direction of decreasing frequencies



Special Functions on AM

Individual Input Circuit Tuning

Holding pressed down the MONO button and turning the tuning knob ii , permits an individual trimming of the input circuit selectivity (indication *PR-SEL).

In doing this, you can essentially reduce the effects of interfering stations. To return to the initial position (automatic input circuit tuning), turn the tuning knob one step upwards or downwards with the MONO button not pressed down.

Bandwidth

With the button iii , the bandwidth can be changed in the wavebands LW, MW and SW. The display will show:

iv = narrow ($\sim \pm 1.9\text{kHz}$)

In this position, it is possible to separate even two closely adjacent stations



v =wide ($\sim \pm 3.4\text{kHz}$)

In this position, the bandwidth is increased to improve the sound quality when receiving stronger stations.

The settings are automatically stored into the memory.

Synchronous Demodulator

If the "narrow" bandwidth setting does not suffice to separate two closely adjacent stations, there still remains the possibility to optimize station tuning by means of the synchronous demodulator.

When tuning to the individual stations with the <TUNING> knob ii and with the Synch-function selected, please observe the following:

When you approach a frequency when tuning in the direction of increasing frequencies, the unit will tune first to the lower and then to the upper sideband and show these in the display.

This is correspondingly opposed when tuning in the direction of decreasing frequencies.

Please see the stylistic representation of the transmitter site with possible interferences.

The Synch Function

After having pressed the SYNCH button, the display will show SYNCH (indication 4) and USB (indication 5).

The tuning steps of the tuning knob ii <TUNING> are switched from 1 kHz to 100 Hz.

With this function, you have the possibility to tune the desired station "away" from the interfering station, and thus distinctly reducing the interfering effect.

You will find the "undistorted sideband" by turning the tuning knob <TUNING> ii .

The Synch function is effective as long as the indications SYNCH and USB (indication 5) or LSB (indication 3) are shown in the display.

So that the synch function can be correctly performed, it is essential that the unit has been correctly tuned to the desired frequency before switching on the Synch function (max. TUNING indication).

Example: The frequency 6085 kHz is distorted by the adjacent station operating with a frequency of 6090 kHz. In this case, you should select the lower side band (LSB) of the frequency 6085 kHz.

To do this, proceed as follows:

Turn the tuning knob <TUNING> ii in the direction of lower frequencies – the indication changes from SYNCH with USB to SYNCH with LSB.

Now turn the tuning knob further in the same direction until the interfering station is sufficiently suppressed and the indications SYNCH with LSB remain visible.

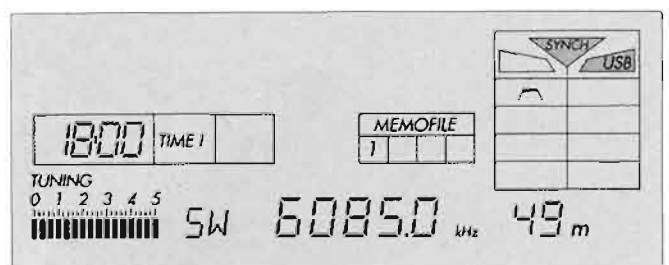
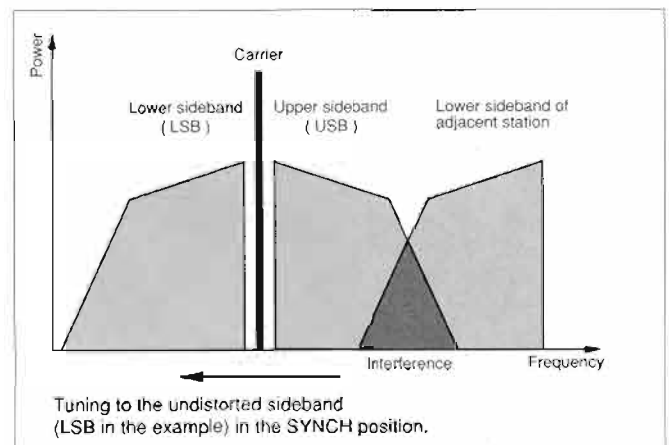

Single Side Band (SSB) Reception on SW

... is an additional function to normal radio reception.

- Switch on your set and tune to a SW amateur band (SSB stations are mainly broadcasted on these bands).
- Reduce the bass tones \mathcal{D} with the bass control $\textcircled{2}$.
- Slowly scan the band step by step for SSB stations with the tuning knob $\langle \text{TUNING} \rangle$ $\textcircled{11}$.

When doing this, please consider that the carrier is suppressed on SSB broadcasts.

For this reason, reception is only possible when the transmitter is actually operating (mostly broadcasting speech). During pauses, tuning is not possible.

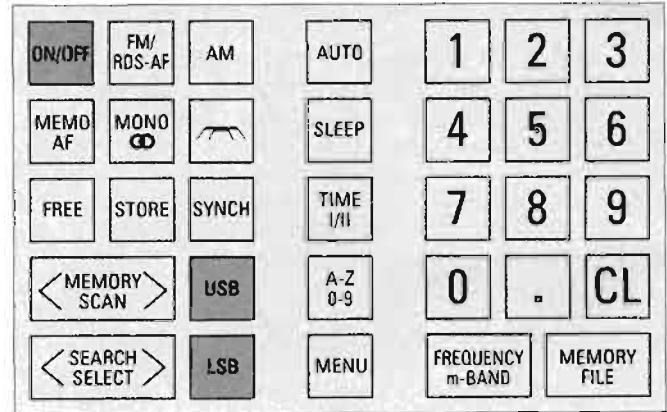

The TUNING indicator $\textcircled{20}$ is of great help when searching SSB stations.

You will notice that the TUNING indication deflects in the rhythm of the speech (modulation) broadcasted by the SSB stations.

- As soon as you have found a station (the speech will still be unintelligible), switch to SSB reception using button LSB (usually for frequencies below 10MHz) or button USB (usually for frequencies above 10MHz).
- Slowly turn the $\langle \text{TUNING} \rangle$ knob $\textcircled{11}$ to find the point of best intelligibility.

If the intelligibility cannot be improved with the TUNING knob, then select the other side band.

- Turn the control AGC \blacktriangle MGC $\textcircled{12}$ to MGC (indication MGC $\textcircled{8}$) and slowly turn further until the station which was muted before can be heard again.

The best setting is reached, when the tuning indication $\textcircled{20}$ deflects in the centre part of its range when a modulated signal (speech) is received.

Use both the MGC control and the volume control for adjusting the volume.

- In the case of strong stations, in the evening, or when interferences should occur, set the local/distant switch SENS DX/LOC $\textcircled{21}$ to LOC.
- Turn the knurled wheel CLARIFY $\textcircled{22}$ slowly up (+) or down (-) to improve the intelligibility.

Even more than normal SW reception, SSB reception may be affected by the following factors:

- Location of reception (shading through buildings)
- Reception conditions (atmosphere)
- Aerial (ideal is a special SW aerial).

If you wish to terminate reception of SSB stations, do not forget to switch back to normal AM radio reception in the following way:

- Press the button LSB or USB once again and set the control AGC \blacktriangle MGC $\textcircled{12}$ to its locking position AGC. The indication MGC $\textcircled{8}$ disappears.

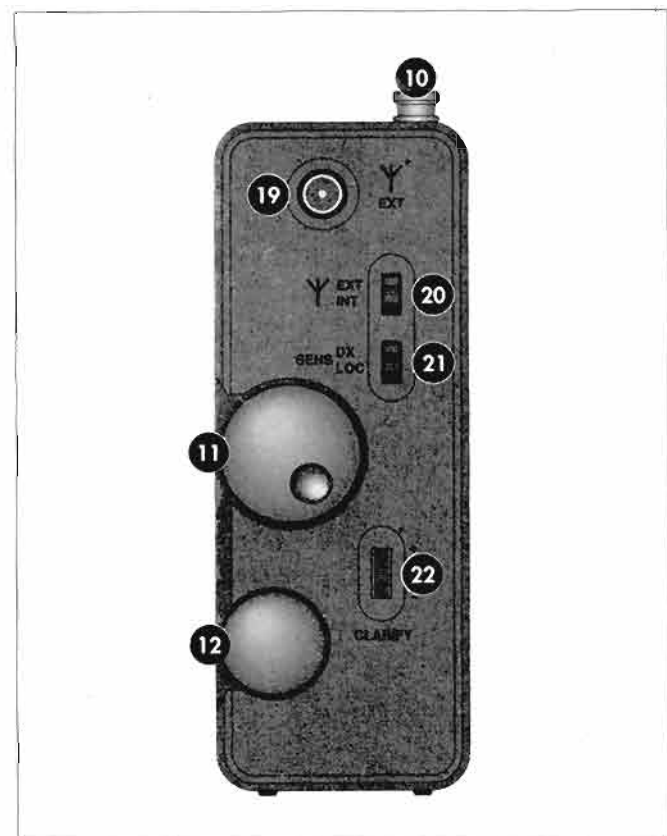
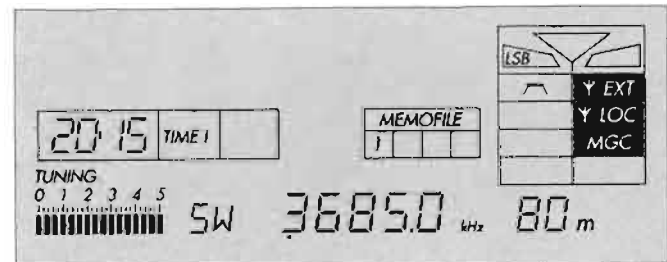

MEMOFILES

You have the possibility to increase the memory capacity of your Satellit 700 by 512 memory positions per MEMOFILE IC (max. 2048).

The sockets for inserting 3 MEMOFILES are to be found behind the trap ③. Technical data for the MEMOFILE Add-on see accompanying data sheet.

1. Fitting a MEMOFILE IC

Ensure that the MEMOFILE IC be inserted with correct polarity.

For this, a mark is provided on the right side below the IC socket which identifies PIN 1 of the socket.

The MEMOFILE IC must be inserted so that the mark for PIN 1 on the MEMOFILE IC coincides with the mark below the IC socket. Before inserting the MEMOFILE, please make sure that no pins of the IC are bent.

Now carefully press the MEMOFILE IC into the respective socket.

When doing this, also observe the numbering of the IC sockets.

This is of importance when later "calling up" the respective MEMOFILES.

2. Removing a MEMOFILE IC

Use the enclosed "pliers" for removing a MEMOFILE IC. The pliers can be found at the right in the MEMOFILE box where they are used in addition to secure the cover of the MEMOFILE box.

3. Calling up a MEMOFILE

The respective MEMOFILE is called up by entering the respective number (1 to 4), by entering a dot, and by pressing the button **MEMORY/FILE**.

Example:

You have fitted the additional MEMOFILES 2 and 4 (MEMOFILE 1 is standard equipment). You can also allocate a name to the MEMOFILES. For this, see the hints on page 55.

If you call up a MEMOFILE position which is not occupied, the error message **** FILE** will appear.

4. Copying a MEMOFILE

The plug-in position for the MEMOFILE 4 serves also for copying the whole contents of MEMOFILES.

The MEMOFILE 4 is then always the copy target file.

As source files you can use the MEMOFILES 1, 2 or 3.

To copy for example the MEMOFILE 2, proceed as follows:

- Insert a MEMOFILE into the plug-in position 4 (target).
- Select the menu function **COPY** - .
- Enter the MEMOFILE source; 2 in the example.
- Confirm the entry with the **MENU** button. Immediately after that copying is started and shown in the display as follows:

Indication:

*-----, **-----, ..., *****-

Important!

All data items stored in MEMOFILE 4 are lost when copying.

- When copying is completed, the indication **COPY** - appears again and further copies can be made (insert another MEMOFILE 4) or the menu can be exited.

Important Information

When not fitted into the unit, protect your MEMOFILES (EEPROMS) against overvoltages which can be generated by static discharges. Store the MEMOFILES in antistatic packings or plug them into conductive foam rubber. Avoid to directly touch the connecting contacts. For further details, please ask your specialized dealer.

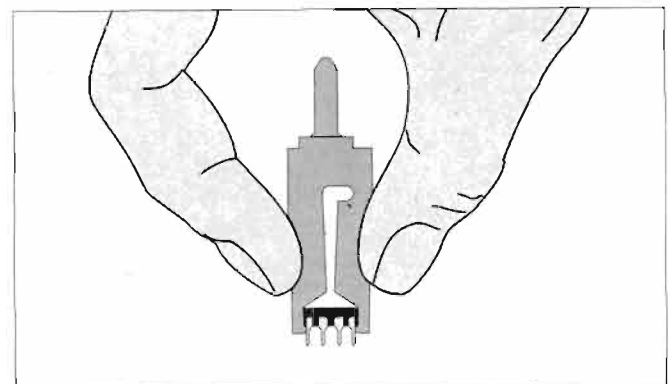
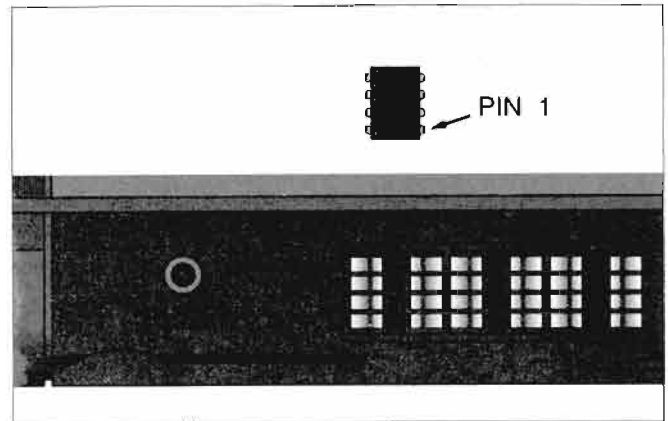

Specification

Power supply requirement

- From batteries: 4 x 1.5V "HP 2" (IEC LR20) or 4 commercially available 4-Ah accumulators of the same size (IEC KR 35/62).
Built-in automatically recharging lithium battery for data protection.

- From external voltage supply: Mains unit NR 90 or 9-12V DC

Output power (MONO and STEREO) in 7.5Ω

- Mains/music power according to DIN 45324: 1 and 2 x 1.5W, resp.
- Peak power: 2 and 2 x 3W, respectively
- Sinus power on battery operation acc. to DIN 45324: 1 or 2 x 0.5W

Battery life (DIN 45314)

- IEC LR 20 (alkaline-manganese)
- eg. VARTA energy 2000 ALKALINE: approx. 90 hours
- eg. Duracell MN 1300: approx. 110 hours
- 4-Ah accumulators (IEC KR 35/62): approx. 25 hours

Built-in aerials

- Telescopic aerial for FM and SW, ferrite rod aerial for MW and LW.

Connecting sockets for

- driving amplifier systems and for mono and stereo tape recordings; LINE OUT (phono sockets).
- headphone with 3.5mm Jack plug; 32 - 2000Ω
- external loudspeaker (left-hand and right-hand channel) with 3.5mm Jack plug; 8Ω
- driving external units, e.g., tape recorders (output switch jack); potential-free relay control
- external power supply, mains unit NR 90 or 9 - 12V DC (5.5mm coaxial socket)
- external aerial DIN 45325 (FM 75Ω/AM 50Ω coaxial socket for all wavebands)

Wavebands

- FM: 87.5 - 108 MHz
- SW: 1612 - 30000 kHz
3950 - 26100 kHz (Satellit Italia)
- MW: 528 - 1611 kHz
- LW: 150 - 353 kHz
- LW: 150 - 302 kHz (Satellit Italia)

Receivable SW Bands

Band	Frequency (kHz)
160-m-amateur	1815 - 1890 (not on Satellit 500 Italia)
120-m-radio	2300 - 2498 (not on Satellit 500 Italia)
90-m-tropic	3200 - 3400 (not on Satellit 500 Italia)
80-m-amateur	3500 - 3800 (not on Satellit 500 Italia)
75-m-radio	3900 - 4000
60-m-tropic	4750 - 5060
49-m-radio	5950 - 6200
41-m-radio	7100 - 7300
40-m-amateur	7000 - 7099
31-m-radio	9500 - 9900
30-m-amateur	10100 - 10150
25-m-radio	11650 - 12050
22-m-radio	13600 - 13800
20-m-amateur	14000 - 14350
19-m-radio	15100 - 15600
17-m-amateur	18065 - 18170
16-m-radio	17550 - 17900
15-m-amateur	21000 - 21449
13-m-radio	21450 - 21850
12-m-amateur	24890 - 24990
11-m-radio	25650 - 26100
10-m-amateur	28000 - 29700

IF: FM = 10.7 MHz, AM IF 1 = 54.5 MHz, IF 2 = 450 kHz

MEMOFILE add-on

CMOS EEPROM's with 2048 x 8 bits
voltage: 3.3 V ± 10 %
see accompanying data sheet

Subject to technical alterations and alterations in styling
E. and O.E.

Hints - Prescriptions - Accessories

Use only a soft cloth which picks up dust to clean the cabinet. Do not use aggressive polishes or cleaning agents. Do not expose the set to temperatures above 60°C. In the case of defects, please consult your specialized dealer. Protect the set against moisture (e.g., dripping or splashing water).

The unit meets the interference radiation regulations CEE 82/499
This set complies with the safety regulations according to VDE 0860 and thus with the international safety regulations according to IEC 65 and CEE 1.

Information on accessories available for your Satellit can be found in the "GRUNDIG Revue" which you can obtain from your dealer.

Radio Stations

Deutsche Welle
D-50588 Köln

Radio Österreich International (RÖI)
A-1136 Wien
Würzburggasse 30

Schweizer Radio International
CH-3000 Bern 15
Giacomettistr. 1

Radio Nederland
P.O. Box 222
NL-1200 JG Hilversum

Radio France Internationale
116 av. du Pres. Kennedy
F 75786 Paris Cedex 16

Radiotelevisione Italiana
Viale Mazzini 14
I-00195 Roma

BBC London External Services
Bush House
London WC2B 4PH

Radio Moskau
Pjatnizkaja 25
Moskva UdSSR

Radio Japan
2 - 2 - 1 Jinnon
Shibuya-ku
Tokyo, Japan